

MAINTENANCE MANUAL

YAMADA PULSATION DAMPENER SERIES

AD Series
AD-TT Series
AD-TT/N Series



WARNING



- For safety reasons, be sure to read this maintenance manual thoroughly before starting maintenance of this product. After reading the manual, keep it in an easy-to-access place so that the user may refer to it whenever necessary.

This maintenance manual describes the items required for maintenance of the YAMADA Pulsation Dampener AD Series, AD-TT Series and AD-TT/N Series.

This document is based on products that were manufactured in March 2011 or sooner. Note that its contents are subject to change as a result of specification changes to be made in future. The units described in this manual are unified into SI units (international system of units).

- Warnings and Cautions

To use this product safely, be sure to observe the contents of the following descriptions. In this manual, warnings and cautions are indicated by using symbols. These symbols are intended to prevent death or serious injury. Each symbol is indicated and has a definition shown below. Read the description with a good understanding of its contents.



WARNING : This indicates the existence of potential hazard which, if not avoided, will result in death or serious injury.



CAUTION : This indicates the existence of potential hazard which, if not avoided, may result in bodily injury or in physical damage.

To indicate the contents of danger and damage, the following symbols are used together with the above indications.



This symbol indicates an act that is prohibited .



This symbol indicates the contents that must be observed.



WARNING



- Before starting maintenance, shut off supply air and clean the pulsation dampener. If air pressure or residual liquid remains in the pulsation dampener, damage or explosion may occur. (For cleaning the pulsation dampener, refer to Chapter 6 of the Operation Manual.)

- When replacing parts, be sure to use the genuine YAMADA parts or equivalents. Using parts other than genuine parts may result in failure. (Refer to Exploded View and Reminder to order correct item on the separate sheets.)



CAUTION



- When it is indicated that dedicated tools should be used, be sure to use these tools, otherwise the pulsation dampener may be damaged.
- Check the weight of the pulsation dampener by referring to 10.1 Main Specifications in the operation manual and take extreme care when lifting it.

Table of Contents

- Warnings and Cautions

- Table of Contents

1. Principles of Operation

| | |
|--|---|
| 1.1 AD-10, AD-25, AD-40 and AD-50 | 1 |
| 1.2 AD-10TT, AD-25TT, AD-38TT, AD-10TT/N and AD-20TT/N | 1 |

2. Tools Required

| | |
|---------------------------|---|
| 2.1 General Tools | 2 |
| 2.2 Dedicated Tools | 2 |
| 2.3 Other | 3 |

3. AD-10, 25, 40, 50, A□, S□, F□, P□, VT Types

| | |
|------------------------|---|
| 3.1 Removal | 4 |
| 3.2 Inspection | 6 |
| 3.3 Installation | 6 |
| 3.4 Torque | 7 |

4. AD-10TT, AD-25TT and AD-38TT

| | |
|------------------------|---|
| 4.1 Removal | 8 |
| 4.2 Inspection | 8 |
| 4.3 Installation | 9 |
| 4.4 Torque | 9 |

5. AD-10TT/N/□, AD-20TT/N/□

| | |
|--|----|
| 5.1 Removal | 10 |
| 5.2 Inspecting the valve | 10 |
| 5.3 Attaching the valve | 11 |
| 5.4 Removing parts | 11 |
| 5.5 Removing the diaphragm and the throat bearing | 11 |
| 5.6 Removal | 13 |
| 5.7 Attaching the diaphragm and the throat bearing | 13 |

1. Principles of Operation

1.1 AD-10, AD-25, AD-40 and AD-50

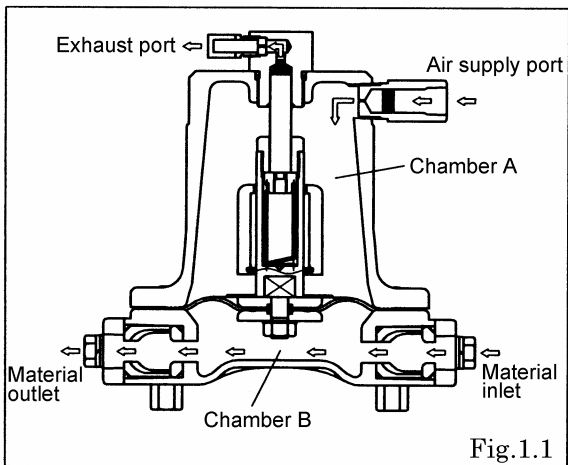

Fig.1.1

When the pressure of chamber B is increased by pulsation caused by pump operation, the diaphragms go up to increase the capacity of chamber B, so that the pressure is absorbed. When the pressure of chamber B is reduced, the diaphragms go down to reduce the capacity of chamber B, so that the pressure is increased. This operation acts as an air cushion to absorb the pulsation of liquid.

When the diaphragms go down to the lower limit, the center rod caused to go down by the diaphragms opens the valve, so that the compressed air in the chamber A is discharged from the exhaust port and the diaphragms are pushed up.

When the diaphragms go up, the air of chamber B is pressed to push down the diaphragms. The diaphragms are always put in the intermediate position by supplying air under the same pressure as that of chamber B, so that the air cushion functions.

1.2 AD-10TT, AD-25TT, AD-38TT, AD-10TT/N and AD-20TT/N

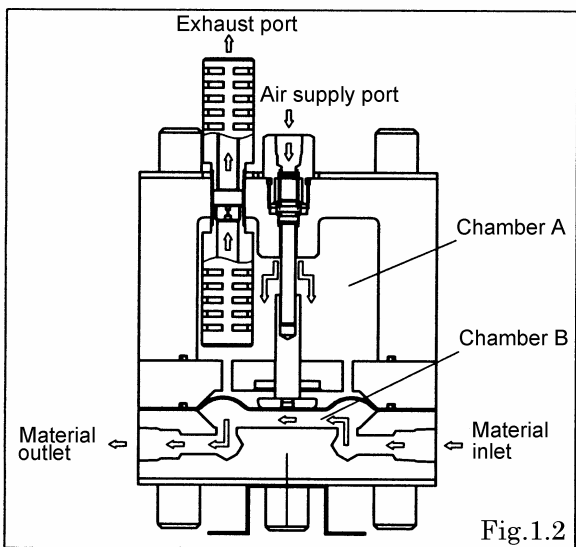

Fig.1.2

When the pressure of chamber B is increased by pulsation caused by pump operation, the diaphragms go up to increase the capacity of chamber B, so that the pressure is absorbed. When the pressure of chamber B is reduced, the diaphragms are caused to go down by the pressure of chamber A to reduce the capacity of chamber B, so that the pressure is increased. This operation acts as an air cushion to absorb the pulsation of liquid.

The compressed air of chamber A is always discharged little by little. When the pressure of chamber A becomes smaller than the pressure of chamber B, the center rod goes up according to the rise of the diaphragms, so that the valve is opened to supply air to chamber A. The diaphragms are always put in the intermediate position by supplying air under higher pressure than the pressure of chamber B, so that the air cushion functions.

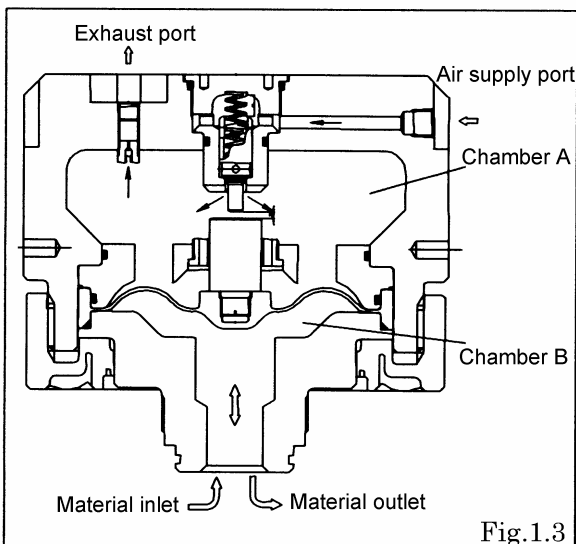

Fig.1.3

2. Tools Required

2.1 General Tools

- Socket Wrenches
 - 13 mm (AD-10, AD-25P□, AD-25VT, AD-10TT)
 - 17 mm (AD-25, AD-40, AD-50, AD-25TT, AD-38TT)
 - 19 mm (AD-40, AD-50 excluding AD-40P□)
 - 22 mm (AD-25A□, AD-25S□, AD-25F□)
 - 24 mm (AD-40□, AD-50A□, AD-50S□, AD-50F□ excluding AD-40P□)
- Box wrench
 - 13 mm (AD-10, AD-25P□, AD-25VT, AD-10TT)
 - 17 mm (AD-10, AD-25, AD-40, AD-50, AD-25TT, AD-38TT)
 - 19 mm (AD-40, AD-50 excluding AD-40P□)
 - 21 mm (AD-10P□)
 - 22 mm (AD-25A□, AD-25S□, AD-25F□)
 - 24 mm (AD-10TT/N, AD-20TT/N)
- For snap ring pliers (AD-10, AD-25, AD-40, AD-50)
- Adjustable angle wrenches
- Hexagonal bar wrench 6 mm (AD-10P□, AD-10TT/N/S, AD-20TT/N/S)
- Flat-blade screwdriver

2.2 Dedicated Tools

- Included tool (accessory)
 - Removal of center disk (AD-25P□, AD-25VT) Part No.771244
- PP wrench (sold separately)
 - Removal of center disk (AD-40P□, AD-50P□) Part No.771868

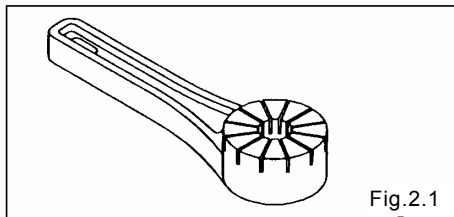

Fig.2.1

- Socket for a guide (optional)
 - Removal of a spring sheet
 - Part number: 804131

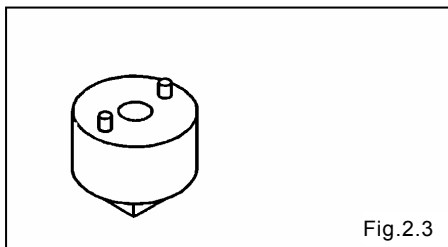

Fig.2.3

- Tweezers for a sleeve (optional)
 - Removal of a guide
 - Part number: 713148

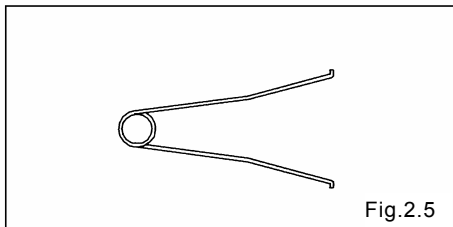

Fig.2.5

- Air chamber wrench (optional)
 - Removal of a ring
 - Part number: 832801

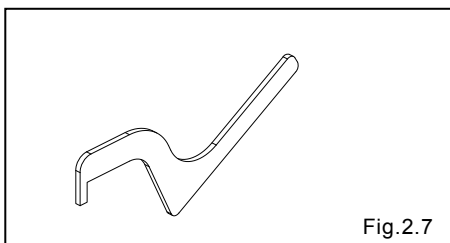

Fig.2.7

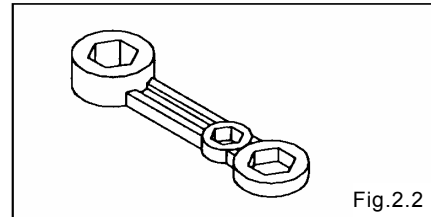

Fig.2.2

- Ring wrench (optional)
 - Removal of a ring
 - Part number: 832802 (for AD-10TT/N)
 - Part number: 832803 (for AD-20TT/N)

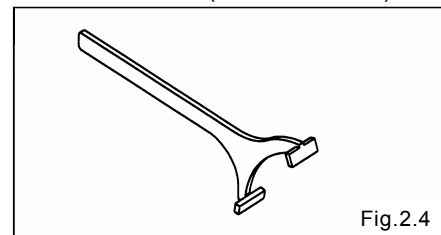

Fig.2.4

- Valve cap opener (supplied with a DP-Fi)
 - Removal of the DP-10Fi or DP-20Fi valve cap
 - Part number: 832517

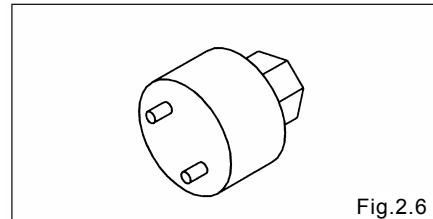

Fig.2.6

2.3 Other

- Grease Urea grease grade (NLGI) No. 2 or equivalent
- Grease SOLVAY SOLEXIS Fomblin® AR555 or equivalent (AD-TT)
- Thread locking agent Equivalent to LOCTITE® 222

3. AD-10, 25, 40, 50, A□ , S□ , F□ , P□, VT Types

3.1 Removal

■ A□, S□ and F□ types

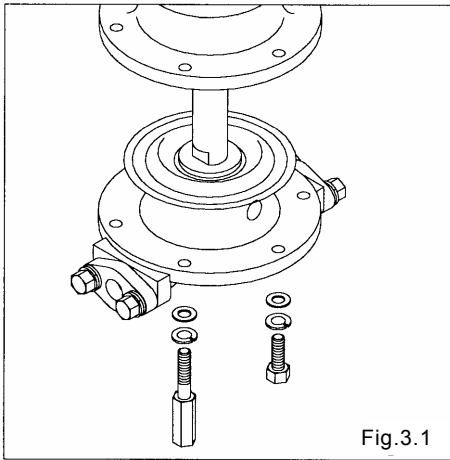

Fig.3.1

- Remove 6 out chamber mounting bolts and studs respectively, and remove the out chamber. (AD-10, AD-25) [Fig.3.1]
- Remove the 8 out chamber locking bolts, studs and nuts respectively, and remove the out chamber. (AD-40, AD-50) [Fig.3.1]
- Pull out the diaphragm, center disk and center rod from the main body. [Fig.3.2]

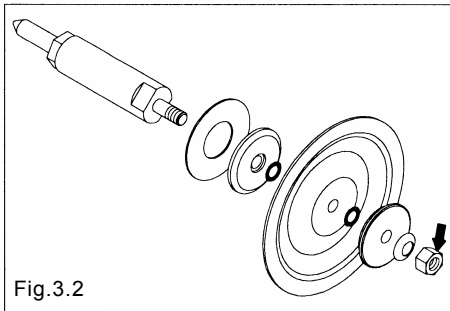

Fig.3.2

- Remove the nut, and remove the center disk, diaphragm and O ring (□T, 10□C, 10□N) from the center rod. [Fig.3.2]
- < NOTE >
- Set the spanner at the 2 way part of the center rod.

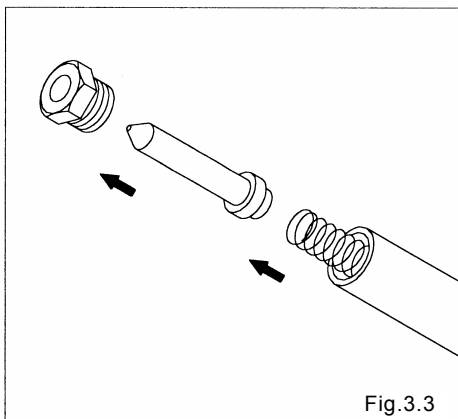

Fig.3.3

- Remove the nut, and remove the valve from the center rod. [Fig.3.3]
- Remove the nut from the valve.
- < NOTE >
- Set the spanner at the 2 way part of the center rod. Take care not to give damage to the slide portion with pipe wrench.

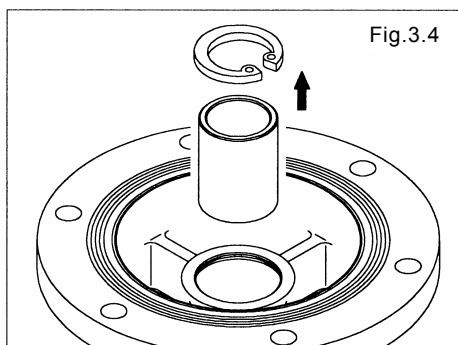

Fig.3.4

- Remove the C type snap ring, and remove the throat bearing from the air chamber. [Fig. 3.4]

■ P□, VT type

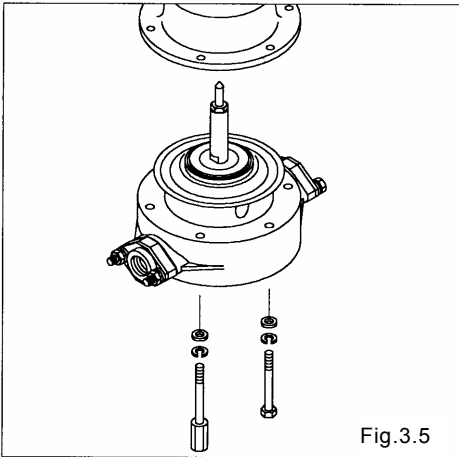

Fig.3.5

- Remove the 6 out chamber locking bolts and studs and remove the out chamber. (AD-10, AD-25) [Fig.3.5]
- Remove the 8 out chamber locking bolts, studs and nuts respectively, and remove the out chamber. (AD-40, AD-50) [Fig.3.5]
- Pull out the diaphragm, center disk and center rod from the main body. [Fig.3.5]

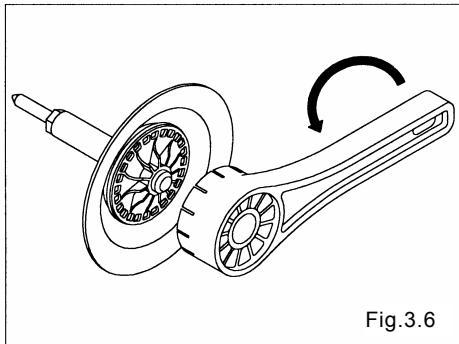

Fig.3.6

- Remove the center disk with supana(21mm), and remove the diaphragm, center disk and O ring (PC, PT) from the center rod. (AD-10P□) [Fig.3.6]
- Remove the center disk with the attached tool (dedicated tool: part No.771244), and remove the diaphragm, center disk and O ring (□T) from the center rod. (AD-25P□, VT) [Fig.3.6]
- Remove the center disk with the PP wrench (dedicated tool: part No.771868), and remove the diaphragm, center disk and O-ring (□T) from the center rod. (AD-40P□, AD-50P□) [Fig.3.6]

<NOTE>

- Set the spanner at the 2 way part of the center rod.

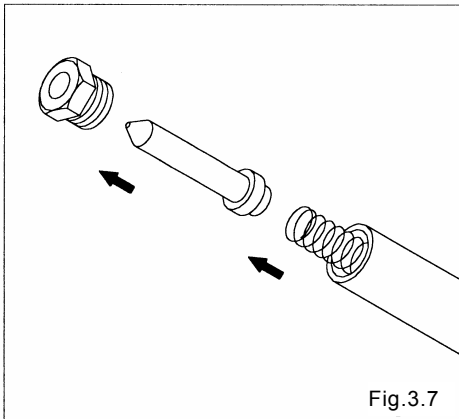

Fig.3.7

- Remove the nut, and remove the valve from the center rod. [Fig.3.7]

<NOTE>

- Set the spanner at the 2 way part of the center rod.
- Be careful not to damage to the slide portion with pipe wrench.

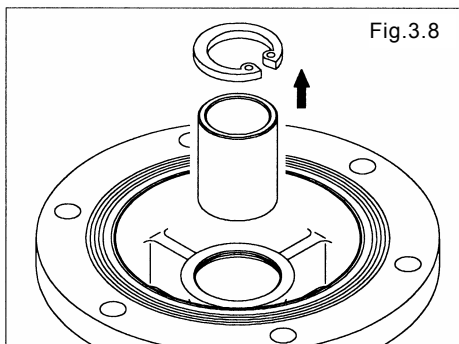
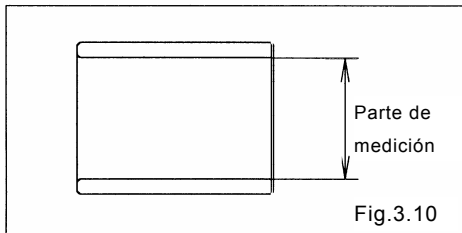
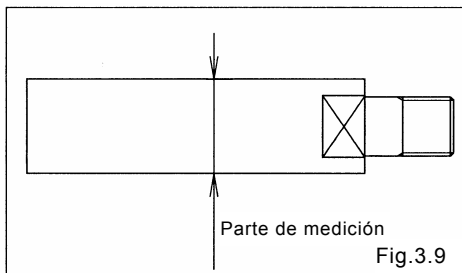

Fig.3.8

- Remove the C type snap ring, and remove the throat bearing from the air chamber. [Fig.3.8]

3.2 Inspection



-Diaphragm

If the diaphragm is worn or damaged, replace it.

As a rule of thumb, replace AD diaphragm every other the pump diaphragm is replaced.

-Center rod [Fig. 3.9]

Measure the diameter. If the diameter is out of the usable range, replace it.

| Usable range |
|---|
| $\Phi 22.28 \sim \Phi 22.38 \text{ mm}$ |

-Throat bearing [Fig. 3.10]

Measure the internal diameter. If the internal diameter is out of the usable range, replace it.

| Usable range |
|---|
| $\Phi 22.47 \sim \Phi 22.63 \text{ mm}$ |

-Valve

If the valve is worn away or damaged, replace it with a new one.

3.3 Installation

For installation, see [Exploded View] on the separate sheet and install in the reverse order of disassembly.

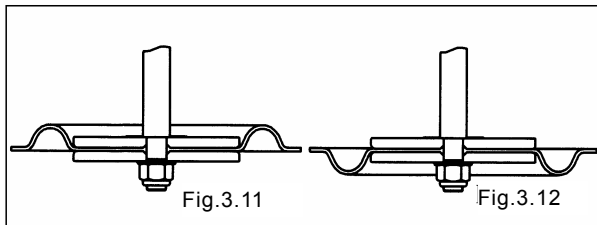

An installation direction of diaphragm.

- AD-10,25 and AD-40,50(□T, □H, □S) of An installation direction of diaphragm.[Fig. 3.11]

- AD-40,50(□C, □N, □E, □V) of An installation direction of diaphragm. [Fig. 3.12]

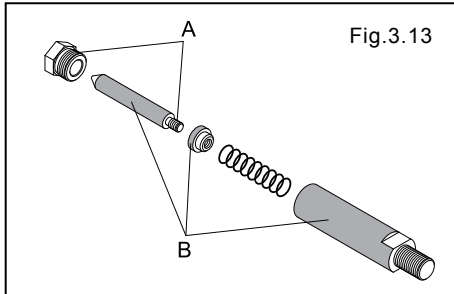

- Apply the screw locking agent and tighten the valve and nut. [Fig. 3.13 A portion]

- Apply the grease on a valve side, a nut and a center rod. [Fig. 3.13 B portion]

- Install the O ring at the center disk. (□T, AD-10□C and AD-10□N) [Fig. 3.14, Fig. 3.15]

- Apply the screw locking agent and tighten the center disk with dedicated tool. (part No.771244 :AD-25P□, VT or part No. 771868 :AD-40P□, AD-50P□)[Fig. 3.15]

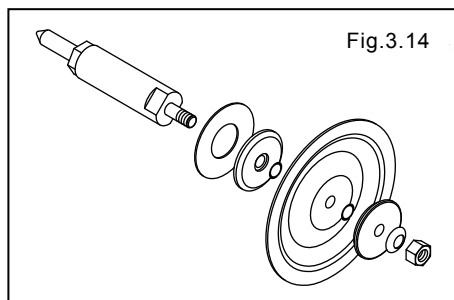

Center rod torque

| AD-10 | | 12 N·m |
|-------|------------|--------|
| AD-25 | □C, □N, □E | 40 N·m |
| | □H, □S, □T | |
| AD-40 | A□, S□, F□ | 60 N·m |
| AD-50 | P□ | 50 N·m |

Valve torque

| | |
|--------------|--------|
| AD-10 | 5 N·m |
| AD-25 | 7 N·m |
| AD-40, AD-50 | 10 N·m |

Out-chamber locking bolt torque

| | Diaphragm material | |
|-------|--------------------|---------|
| | C, N, E | H, S, T |
| AD-10 | 12 N·m | |
| AD-25 | 10 N·m | 20 N·m |
| AD-40 | 40 N·m | |
| AD-50 | 35 N·m | |

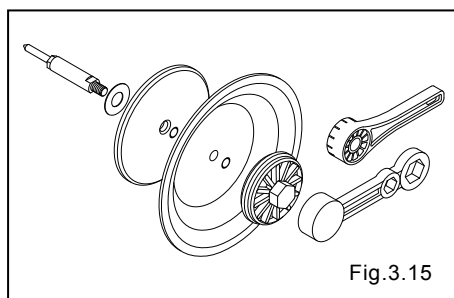

< NOTE >

- Torque bolts diagonally for uniform force.

- Take care about the installation direction of the conical spring.

3.4 Torque

■ Plastic type

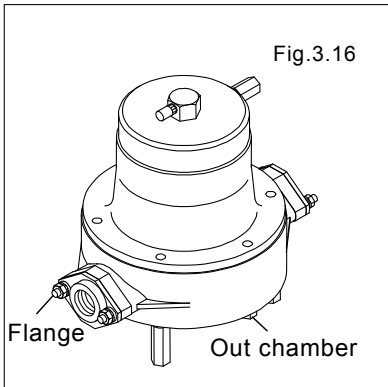

- The torque should be applied on the occasion of
 - (1) Immediately before you operate the dampener for the first time.
 - (2) Liquid leakage is found at routine inspection.

| | | Bolt (Out chamber) | Nut (Flange) |
|-------|-------------------------------|--------------------|--------------|
| AD-10 | PC, PT, PS | 12 N•m | 8 N•m |
| AD-25 | PC | 10 N•m | 10 N•m |
| | PT, VT | 20 N•m | 12 N•m |
| | PH | 20 N•m | 10 N•m |
| AD-40 | PC, PN, PE, PV, PT, PH, PS | 35 N•m | 20 N•m |
| AD-50 | PC, PN, PE, PV, PT, PH, PS | 35 N•m | 20 N•m |

<NOTE>

- Torque bolt diagonally for uniform force.
- Retighten the out chamber and then the flange in this order.
[Fig.3.16] (Fig.3.16 shows the AD-25P□.)

■ Metal type

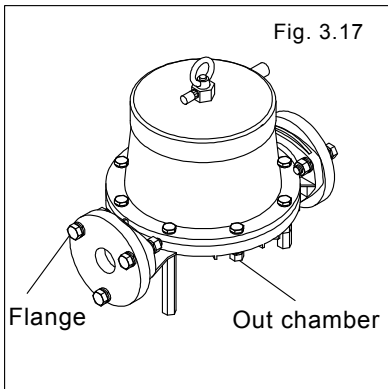

- The torque should be applied on the occasion of
 - (1) Immediately before you operate the dampener for the first time.
 - (2) Liquid leakage is found at routine inspection.

| | | Bolt (Out chamber) | Nut (Flange) |
|-------|-------------------------------|--------------------|--------------|
| AD-10 | □C, □N, □T, □H | 12 N•m | 12 N•m |
| AD-25 | □C, □N, □E | 10 N•m | 10 N•m |
| | □T | 20 N•m | 35 N•m |
| | □H | 20 N•m | 10 N•m |
| AD-40 | □C, □N, □E, □V, □T, □H, □S | 40 N•m | 20 N•m |
| AD-50 | □C, □N, □E, □V, □T, □H, □S | 40 N•m | 20 N•m |

<NOTE>

- Torque bolt diagonally for uniform force.
- Retighten the out chamber and then the flange in this order.
[Fig.3.17] (Fig.3.17shows the AD-40A□.)

4. AD-10TT, AD-25TT and AD-38TT

4.1 Removal

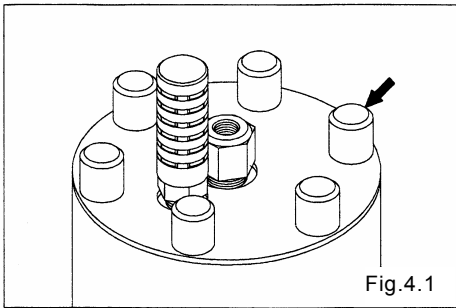

- Remove the 6 upper and lower caps at the both ends of the tie rod. (8 caps each in the AD-38TT)
- Remove the 6 upper and lower nuts at both ends of the tie rod (8 nuts each in the AD-38TT), and remove the out-chamber, diaphragm and air chamber B. [Fig. 4.1]

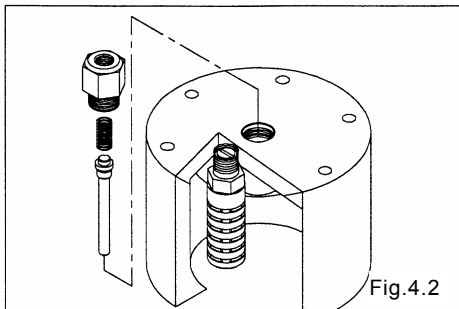

- Remove the union, and remove the spring and valve from air chamber A. [Fig. 4.2]

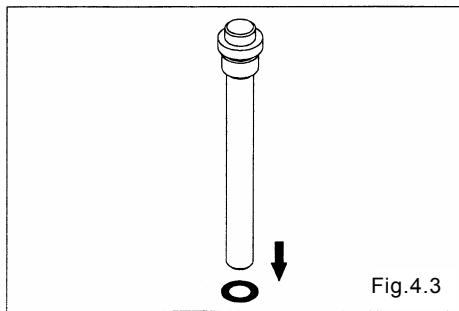

- Remove the O ring from the valve. [Fig. 4.3]

4.2 Inspection

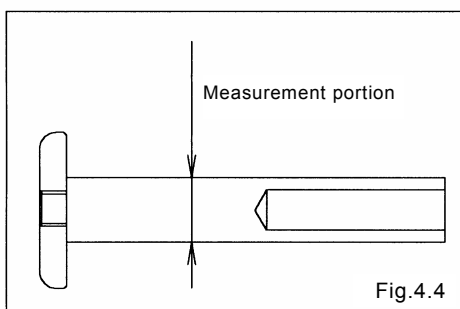

- Diaphragm
If the diaphragm is worn or damaged, replace it.
As a rule of thumb, replace AD diaphragm every other the pump diaphragm is replaced.

- Rod [Fig. 4.4]
Measure the diameter. If the diameter is out of the usable range, replace it with a new one

Usable range

| | |
|--------------------|--------------------|
| AD-10TT AD-25TT | Φ11.80 ~ Φ12.00 mm |
| AD-38TT | Φ17.80 ~ Φ18.00 mm |

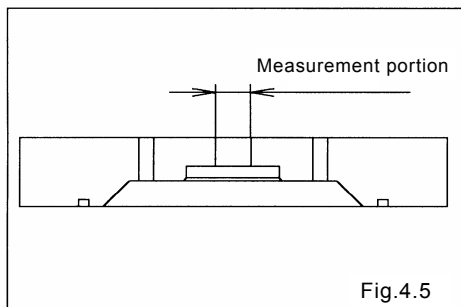

- Air chamber B [Fig. 4.5]
Measure the internal diameter. If the internal diameter is out of the usable range, replace it with a new one.

| Usable range | |
|--------------------|---------------------------------|
| AD-10TT AD-25TT | $\Phi 12.05 \sim \Phi 12.50$ mm |
| AD-38TT | $\Phi 18.05 \sim \Phi 18.50$ mm |

- O ring
If the O ring is worn away or damaged, replace it with a new one.

4.3 Installation

For installation, see [Exploded View] on the separate sheet and install in the reverse order of disassembly.

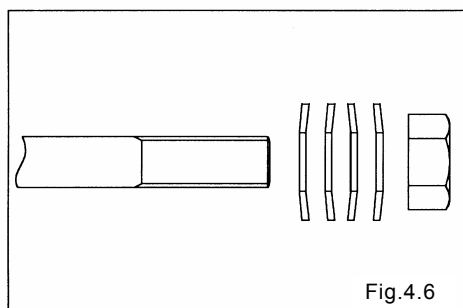

- Install the diaphragm with its convex side upward.

| Union torque | |
|--------------------|-------|
| AD-10TT | 5 N·m |
| AD-25TT AD-38TT | 7 N·m |

| Tie rod torque | |
|----------------|--------|
| AD-10TT | 7 N·m |
| AD-25TT | 10 N·m |
| AD-38TT | 15 N·m |

<NOTE>

- Take care not to admit foreign materials or give damage onto the seal surface.
- Tighten the bolts diagonally by uniform force.
- Take care about the installation direction of the conical spring. [Fig. 4.6]
- Perform tightening completely immediately before use. (Refer to 5.5 Torque)

4.4 Torque

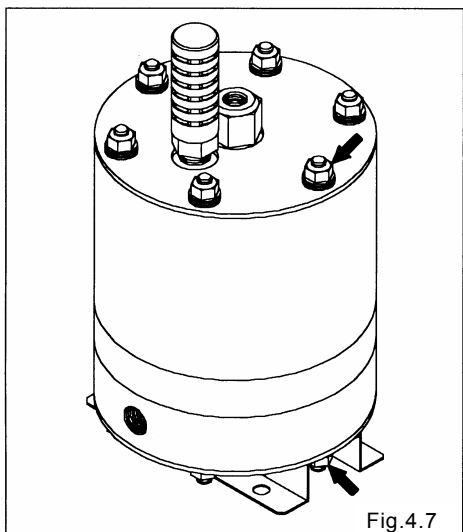

- Regarding the AD-10TT, AD-25TT and AD-38TT, there is potential that dimensional changes may be caused by operating temperature and secular changes due to properties of resin material. Accordingly, check each seal part for leakage and perform torque periodically.
- In the following cases, perform torque.
 - (1) Immediately before you operate the dampener for the first time
 - (2) When the dampener is inspected every three months after installation.
(Every six months when it is used at a place whose temperature is from - 5°C to + 5°C such as a clean room)
 - (3) When the dampener restarts at low temperature if the environment or the temperature of liquid is hot while it is operating and low while it stops.
 - (4) Liquid leakage is found at routine inspection.

| Tie rod torque | |
|----------------|--------|
| AD-10TT | 6 N·m |
| AD-25TT | 8 N·m |
| AD-38TT | 13 N·m |

< NOTE >

- Torque nuts (tie rods) diagonally for uniform force. (Fig.4.7 shows the AD-10TT.)

5. AD-10TT/N/□, AD-20TT/N/□

5.1 Removal

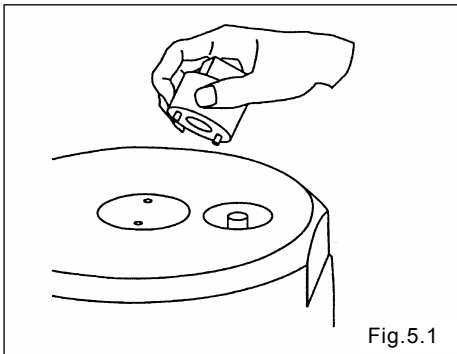

- Use the dedicated tool 1, a socket for a guide (option 804131) and a 24mm wrench to remove the spring sheet. [Fig. 5.1 and Fig. 5.2]

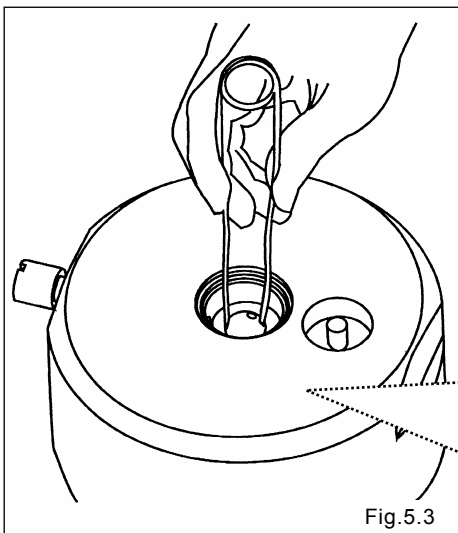
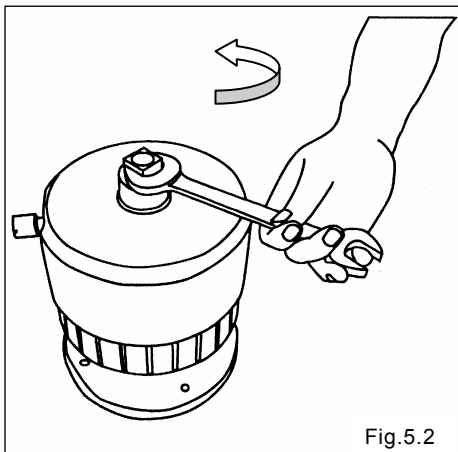

- Remove springs (two). [Fig. 5.4]
- Remove the valve. [Fig. 5.4]
- Use the dedicated tool, tweezers for a sleeve (part number: 713148) to hook a hexagonal bar wrench over the hole of the valve guide, and pull out the valve guide. [Fig. 5.3]

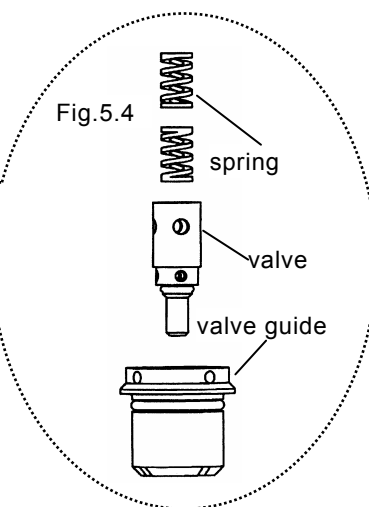

5.2 Inspecting the valve

- If the valve is worn out or damaged, replace it with a new one.

5.3 Attaching the valve

For installation, see [Exploded View] on the separate sheet and install in the reverse order of disassembly.

<NOTE>

- Apply grease to the valve guide and the O ring of the spring sheet.
- Be careful not to make the spring fall down to be assembled into the valve.

5.4 Removing parts

■ Removing the base (AD-10TT/N/S, AD-20TT/N/S)

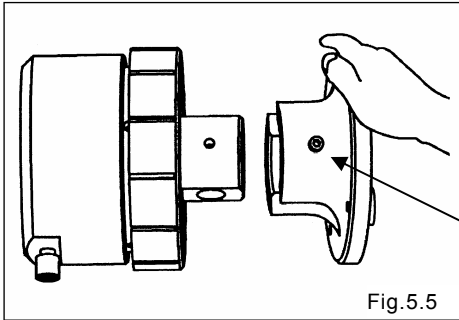

- Use a hexagonal bar wrench (6 mm) to loosen the setscrews of the base (two), and remove the base. [Fig.5.5]

Setscrew of the base

■ Removing the dampener from the pump (AD-10TT/N/M, AD-20TT/N/M)

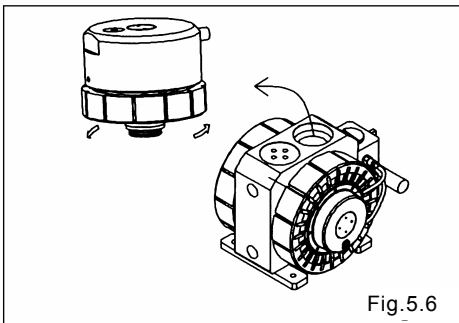

- Remove the dampener from the pump.
- Turn the dampener main unit to remove it from the pump. [Fig. 5.6]

5.5 Removing the diaphragm and the throat bearing

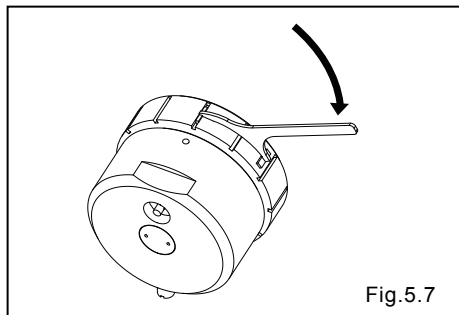

- Use the dedicated tool "ring wrench" (part number: 832802 for AD-10TT/N or 832803 for AD-20TT/N) to remove the ring. [Fig. 5.7, 5.8]

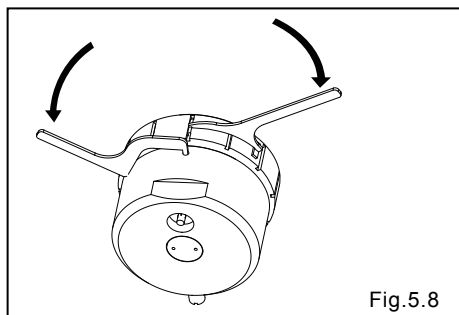

- If you can't remove the ring, use the " Air chamber wrench" (part number: 832801) . [Fig.5.8]

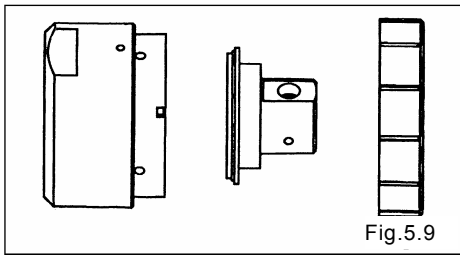

Fig.5.9

- Remove the out chamber. [Fig. 5.9]

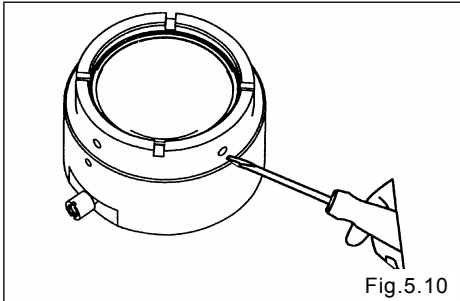

Fig.5.10

- Insert a flat blade screwdriver into the hole (four) of the air chamber to push up the diaphragm. [Fig. 5.10]

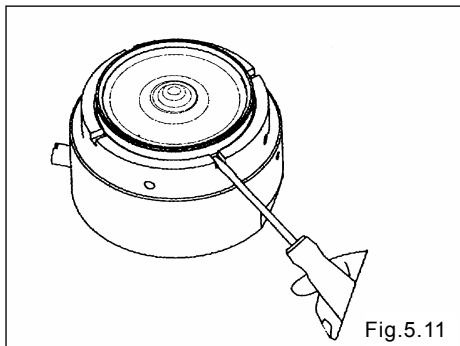
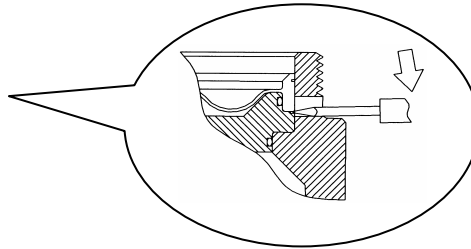

Fig.5.11

- Insert the flat-blade screwdriver from the notch (four) of the air chamber into the groove of the diaphragm to push up the diaphragm.
- Remove the diaphragm. [Fig. 5.11]

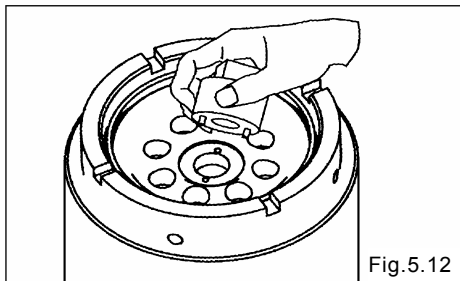
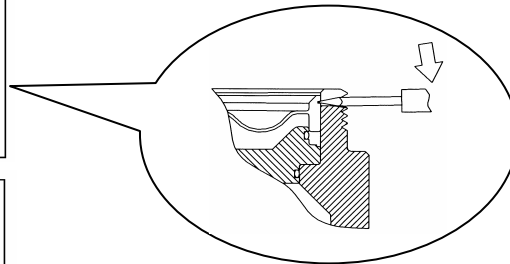

Fig.5.12

- Use the dedicated tool 1, a socket for a guide (option: part number 804131) and a 24mm wrench to remove the throat bearing. [Fig. 5.12, Fig. 5.13]

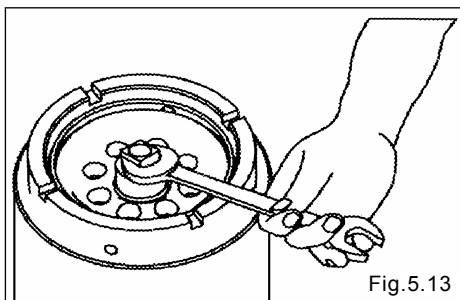

Fig.5.13

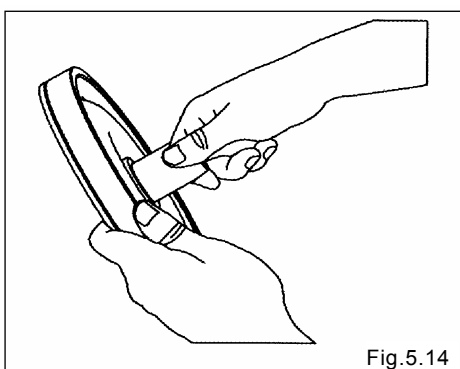

Fig.5.14

- Remove the center rod from the diaphragm. [Fig. 5.14]

5.6 Removal

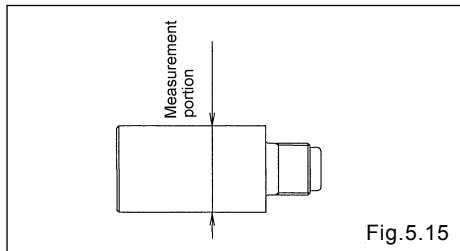

Fig.5.15

- Diaphragm

If the diaphragm is worn or damaged, replace it.

As a rule of thumb, replace AD diaphragm every other the pump diaphragm is replaced.

- Center rod [Fig. 5.15]

Measure the diameter. If the diameter is out of the usable range, replace it with a new one.

Usable range

| | |
|-------------|--------------------|
| AD-10TT/N/□ | Φ19.90 ~ Φ19.98 mm |
| AD-20TT/N/□ | Φ23.90 ~ Φ23.98 mm |

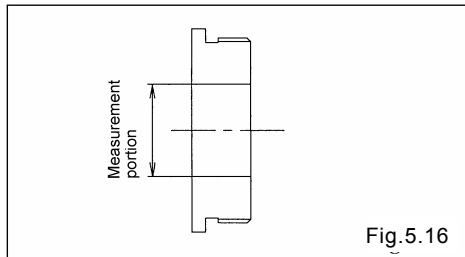

Fig.5.16

- Throat bearing [Fig. 5.16]

Measure the internal diameter. If the internal diameter is out of the usable range, replace it with a new one.

Usable range

| | |
|-------------|--------------------|
| AD-10TT/N/□ | Φ20.03 ~ Φ20.15 mm |
| AD-20TT/N/□ | Φ24.03 ~ Φ24.15 mm |

- O ring

If the O ring is worn away or damaged, replace it with a new one.

5.7 Attaching the diaphragm and the throat bearing

Follow the reverse procedure to removal of each part.

Attaching the center rod

| | |
|-------------|---|
| AD-10TT/N/□ | Screw in the center rod until it stops against the diaphragm, and screw it in further by 5° to 10°. |
| AD-20TT/N/□ | |

Attaching the throat bearing

| | |
|-------------|---|
| AD-10TT/N/□ | Screw in the throat bearing until it stops against the air chamber B, and screw it in further by 5° to 10°. |
| AD-20TT/N/□ | |

Attaching the ring

| | | |
|-------------|--------------|---|
| AD-10TT/N/□ | New O ring | Screw in the ring until it stops against the air chamber A, and screw it in further by 45°. |
| AD-20TT/N/□ | Reuse O ring | Screw in the ring until it stops against the air chamber A, and screw it in further by 20°. |

<NOTE>

Reference ring tightening torque

| | | |
|-------------|--------------|----------|
| AD-10TT/N/□ | New O ring | 60 N · m |
| AD-20TT/N/□ | Reuse O ring | 40 N · m |

When the tightening torque of the ring is measured, I will recommend the use of the Interchangeable type pre lock torque wrench (marketed commodity) along with dedicated tool "Ring wrench". Please consult in detail with the dealer or our Sales office.

Manufactured by

YAMADA CORPORATION

INTERNATIONAL DEPARTMENT

No.1-3, 1-Chome, Minami-Magome, Ohta-Ku, Tokyo, 143-8504, Japan

PHONE : +81-(0)3-3777-0241

FAX : +81-(0)3-3777-0584

201112 NDP196M