

MAINTENANCE MANUAL

YAMADA AIR-OPERATED DIAPHRAGM PUMPS

NDP-5
NDP-15

WARNING



- For your own safety, be sure to read these procedures carefully before performing maintenance on this product. After reading this document, be sure to keep it handy for future reference.

This maintenance manuals cover what you should know about maintenance of the Yamada NDP-5 series and NDP-15 series Diaphragm Pumps.

This edition is based on the standards for the March 2008 production run. Remember, the specifications are always subject to change; therefore, some of the information in this edition may not apply to new specifications.

Warnings and Cautions

For safe use of this product, be sure to note the following: In this document, warnings and cautions are indicated by symbols. These symbols are for those who will operate this product and for those who will be nearby, for safe operation and for prevention of personal injury and property damage. The following warning and caution symbols have the meanings described below. Be sure to remember their meanings.



WARNING: If you ignore the warning described and operate the product in an improper manner, there is danger of serious bodily injury or death.



CAUTION : If you ignore the caution described and operate the product in an improper manner, there is danger of personal injury or property damage.

Furthermore, to indicate the type of danger and damage, the following symbols are also used along with those mentioned above:



This symbol indicates a DON'T, and will be accompanied by an explanation on something you must not do.



This symbol indicates a DO, and will be accompanied by instructions on something you must do in a certain situation.

WARNING



- Before starting maintenance work, cut off the feed air and clean the pump. If air pressure or residue remain in the pump, there is danger of explosion, or possible poisoning resulting in serious injury or death if chemicals adhere to the skin or are accidentally swallowed. (For details on cleaning the pump, refer to Chapter 6 of the operating manual.)
- When replacing parts, be sure to use the recommended genuine parts or Equivalents. Use of other parts may cause a malfunction of the product.

CAUTION



- When it is instructed that special tools must be used, be sure to use the specified tools. Otherwise, the pump may be damaged.
- Refer to 10.1 "Specifications" in the Operating Manual. Also, remember that the pump is heavy, and extreme care must be taken when lifting it.

Table of Contents

| | |
|--|----|
| ·Warnings and Cautions | |
| ·Table of Contents | |
| 1.Principles of operation | 1 |
| 2.Tools, etc. | |
| 2.1 General tools | 1 |
| 2.2 Special tools | 1 |
| 2.3 Misc. | 1 |
| 3.Ordering Replacement parts | 1 |
| 4.Balls, Flat valves and Valve seats | |
| 4.1 Removal | |
| ■FAT, FST, BA□, BS□ types | 2 |
| ■FP□, FV□, FDT types | 3 |
| 4.2 Inspection | |
| ■Ball valve types | 4 |
| ■Flat valve types | 4 |
| 4.3 Installation | 4 |
| 5.Diaphragm and Center rod | |
| 5.1 Removal | |
| ■FAT, FST, BA□, BS□ types | 5 |
| ■FP□, FV□, FDT types | 6 |
| 5.2 Inspection | 6 |
| 5.3 Installation | |
| ■B□H, B□S, FPH, FPS types | 7 |
| ■B□C, B□N, B□T, FPC, FPN, F□T types | 7 |
| 6.Pilot valve Assembly, Guide and Bushing | |
| 6.1 Removal | |
| ■NDP-5 | 8 |
| ■NDP-15 | 8 |
| 6.2 Inspection | 8 |
| 6.3 Installation | 8 |
| 7.C spool valve Assembly and Sleeve Assembly | |
| 7.1 Removal | 9 |
| 7.2 Inspection | 9 |
| 7.3 Installation | 9 |
| 8.Retightening of Tie rods | 10 |
| 9.Exploded View and Parts List | |
| 9.1 NDP-5 FAT•FST | 11 |
| 9.2 NDP-5 FPT•FVT•FDT | 13 |
| 9.3 NDP-15 BA□•BS□ | 15 |
| 9.4 NDP-15 FP□•FV□•FDT | 17 |
| 9.5 NDP-15 BODY ASSEMBLY | 19 |

1.Principles of operation

There are two diaphragms fixed to the center rod, one at each end. When compressed air is supplied to air chamber b (right side, see Fig. 1.1), the center rod moves to the right, the material in material chamber B is pushed out, and at the same time material is sucked into material chamber A.

When the center rod is moved full-stroke to the right, the air switch valve is switched, compressed air is sent to air chamber a (left side, see Fig.1.2), and the center rod moves to the left. The material in material chamber A is pushed out, and at the same time material is sucked into material chamber B.

Through repetition of this operation, material is repeatedly taken in and discharged out.

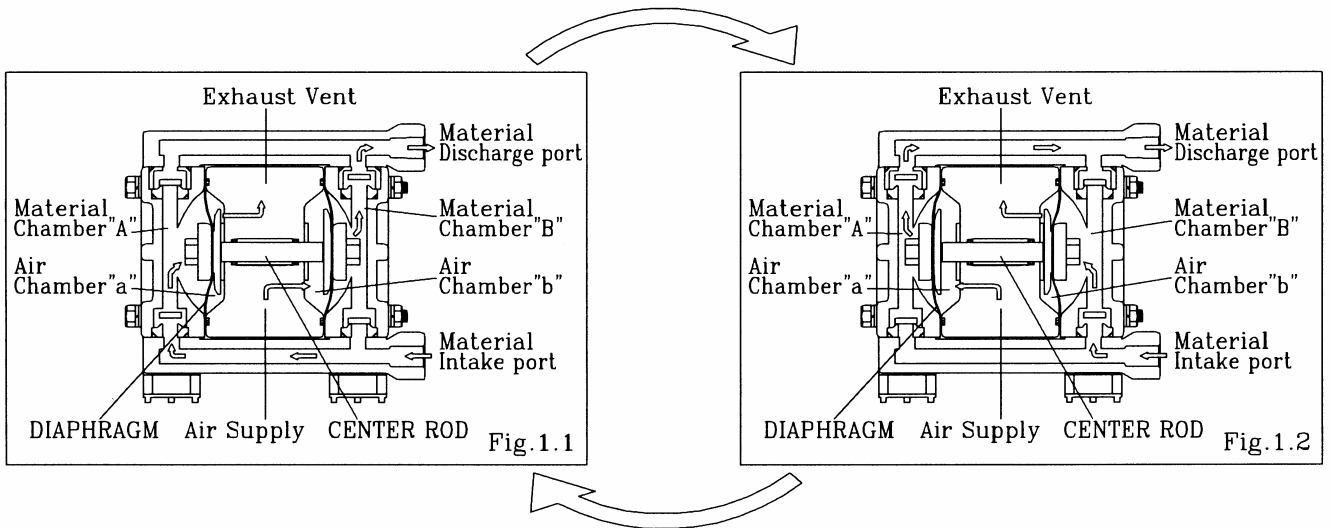

2.Tools, etc.

2.1 General tools

- Socket wrenches 10mm(NDP-5), 13mm(NDP-15)
- Open-end wrenches 10mm (NDP-5), 13mm(NDP-15), 21mm(NDP-15)
- Plyer

2.2 Special tools (sold separately)

- Cap and disk remover
Purpose: Removing the center disk of
FP□ and FVT and FDT types
- Sleeve remover
Purpose: For removing sleeves

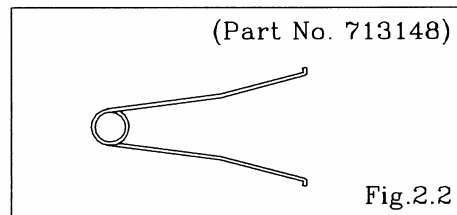
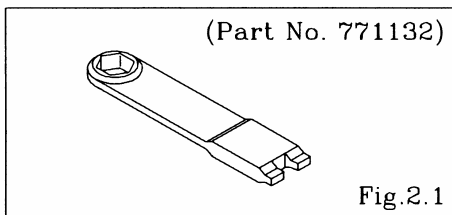

2.3 Misc.

- Assembly oil Turbine oil none addition class 1(equivalent to ISO VG32 grade)
- Nuts M6 x 1(NDP-5), M8 x 1.25(NDP-15)
- Grease Urea grease grade (NLGI) No.2

3.Ordering Replacement parts

For accurate and speedy shipment of parts, be sure to order the right parts for your model to distributor. Indicate the part numbers, descriptions, and quantities.

4.Balls, Flat valves and Valve seats

4.1 Removal

■ FAT, FST, BA□, BS□ types

See [9.Exploded View] on after p.11. (Fig. 4.1, 4.2, 4.3 and 4.4 show the NDP-5 FAT.)

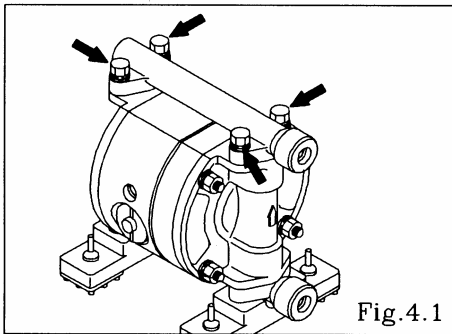

- Remove the 4 retainer bolts from the out manifold, and remove the out manifold. [Fig.4.1]

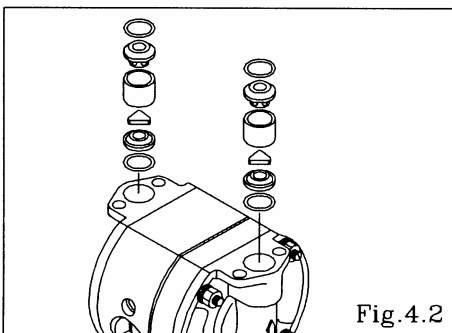

- Remove the O ring, valve stopper, valve guide, flat valve and valve seat. (NDP-5) [Fig.4.2]
- Remove the O ring, valve guide, ball and valve seat. (NDP-15) [Fig.4.2]

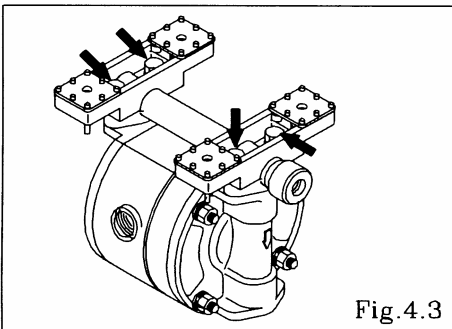

- Turn over the main body assembly. [Fig.4.3]
- Remove the 4 retainer bolts from the in manifold, and remove the base and in manifold. [Fig.4.3]

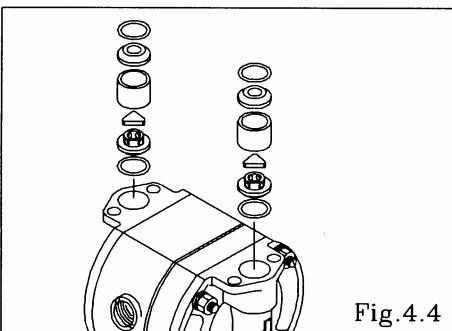

- Remove the O ring, valve seat, flat valve, valve guide and valve stopper. (NDP-5) [Fig.4.4]
- Remove the O ring, valve seat, ball and valve guide. (NDP-15) [Fig.4.4]

■FP□, FV□, FDT types

See [9.Exploded View] on after p.11. (Fig. 4.5, 4.6, 4.7 and 4.8 show the NDP-5 FPT.)

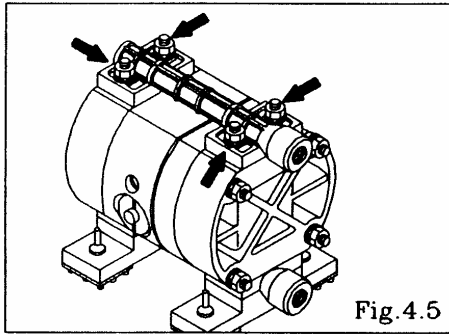

- Remove the 4 retainer nuts from the out manifold, and remove the out manifold. [Fig.4.5]

< NOTE >

- When the retainer nuts both side of the tie rod remove, the in manifold removes.(NDP-5)

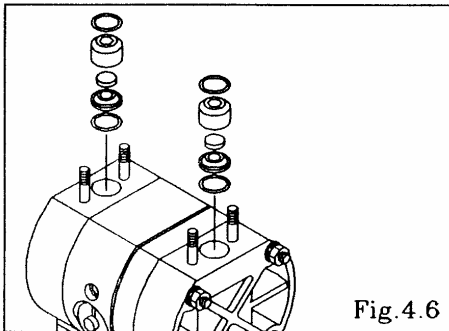

- Remove the O ring, valve stopper, flat valve and valve seat. [Fig.4.6]

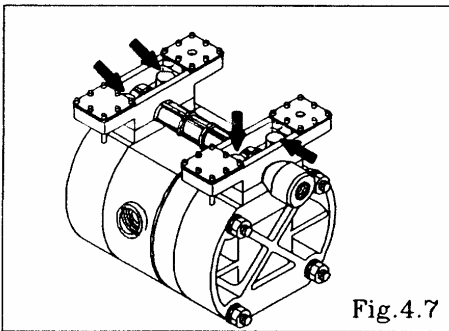

- Turn over the main body assembly. [Fig.4.7]
- Pull out the bolt, and remove the base and in manifold. (NDP-5)
- Remove the 4 retainer bolts from the in manifold, and remove the base and in manifold. (NDP-15) [Fig.4.7]

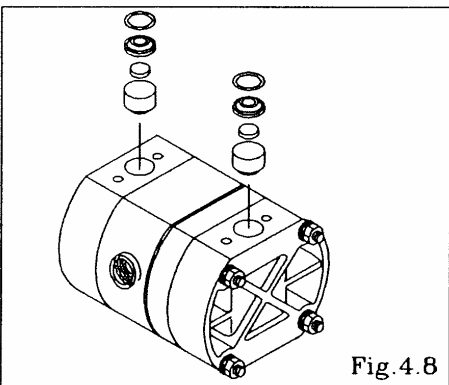

- Remove the O ring, valve seat, flat valve and valve stopper. [Fig.4.8]

4.2 Inspection

■ Ball valve type

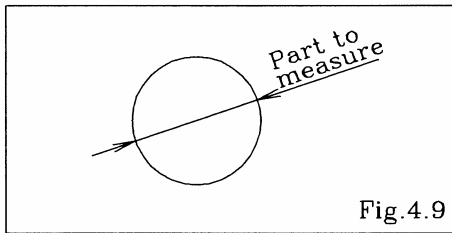

- Ball [Fig.4.9]
Measure the outside diameter, and if it is outside the usable range, replace the ball.

| Usable range of Ball | |
|----------------------|----------------------|
| NDP-15 | Sø 20.0 ~ Sø 22.8 mm |

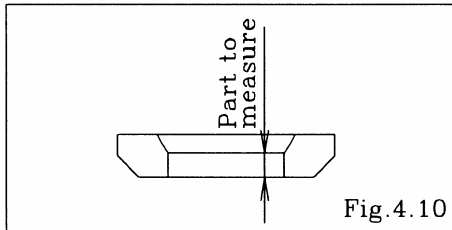

- Valve seat [Fig.4.10]
Measure the dimension shown at left, and if it is outside the usable range, replace the seat.

| Usable range of Valve seat | |
|----------------------------|--------------|
| NDP-15 | 2.6 ~ 6.5 mm |

■ Flat valve type

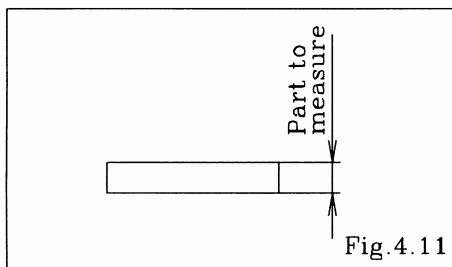

- Flat valve [Fig.4.11]
Measure the dimension shown at left, and if it is outside the usable range, replace the seat. If the seal ring is worn out or cracked, replace it.

| Usable range of Flat valve | |
|----------------------------|--------------|
| NDP-5 | 2.5 ~ 3.1 mm |
| NDP-15 | 4.3 ~ 5.0 mm |

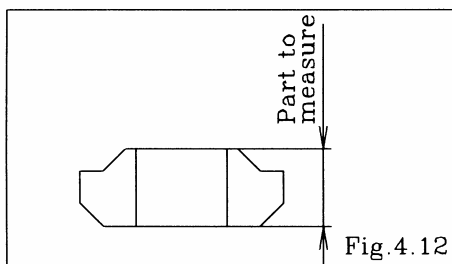

- Valve seat [Fig.4.12]
Measure the dimension shown at left, and if it is outside the usable range, replace the seat.

| Usable range of Valve seat | |
|----------------------------|---------------|
| NDP-5 | 5.8 ~ 7.1 mm |
| NDP-15 | 8.2 ~ 10.0 mm |

- O ring (other than PTFE)
If O rings is worn out or cracked, replace it.

4.3 Installation

For installation, see [9. Exploded View] on after p.11, and install in the reverse order of disassembly.

| Tightening torque for manifold retainer bolts or nuts | |
|---|---------|
| NDP-5 | 7.5 N·m |
| NDP-15 | 12 N·m |

< NOTE >

- Make sure there is no dust on the seal surface and the seal is not damaged.
- Replace the PTFE O ring regardless of its condition.

5. Diaphragm and Center rod

5.1 Removal

■ FAT, FST, BA□, BS□ types

See [9. Exploded View] on after p.11. (Fig. 5.1, 5.2 and 5.3 show the NDP-5 FAT.)

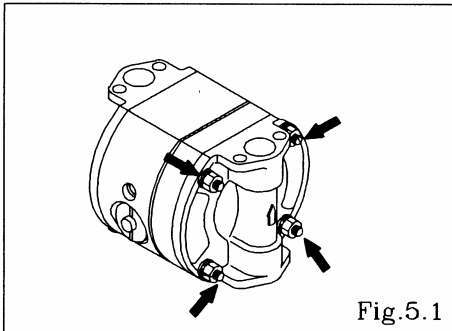

- Remove the ball or flat valve and valve seat (see [4.1 Removal FAT, FST, BA□, BS□ types] on p.2).
- Remove the 8 (12 on the NDP-15) retainer bolts from the out chamber, and remove the out chamber. [Fig.5.1]

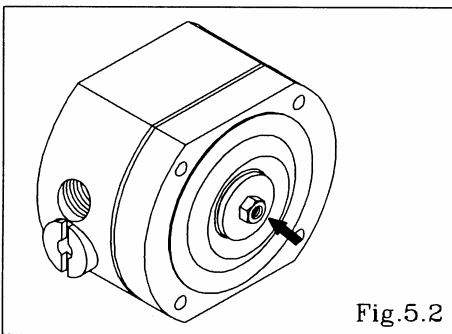

- Remove the nuts on both sides of the center rod. [Fig.5.2]
- After the nuts on one side have been removed, remove the center disk and diaphragm. Remove the diaphragm, center disk and center rod from the opposite side of the main body.

<NOTE>

- When the diaphragms are removed, the main body is separated 2 pieces. For easy work, leave the tie rods or bolts fastened temporarily before remove the diaphragms.

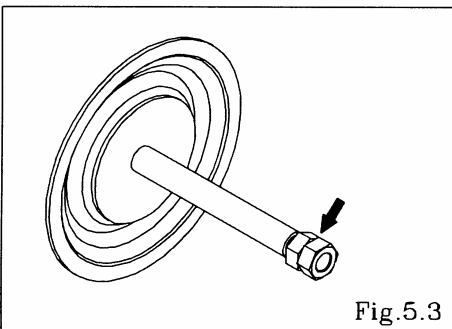

- Remove the nuts on the opposite side using the double nuts. [Fig.5.3]
- Remove the coned disk spring, center disk and diaphragm.

■FP□, FV□, FDT types

See [9. Exploded View] on after p.11. (Fig. 5.4, 5.5 and 5.6 show the NDP-5 FPT.)

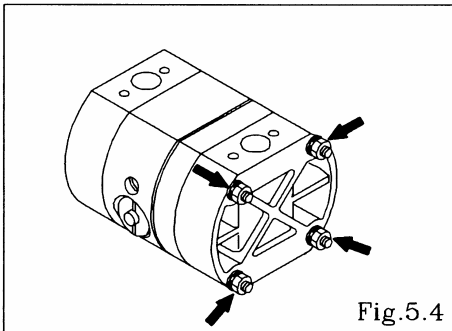

- Remove the flat valve and valve seat (see [4.1 Removal FP□, FV□, FDT types] on p. 3).
- Remove the 8 (12 on the NDP-15) retainer nuts from the out chamber, and remove the out chamber. [Fig.5.4]

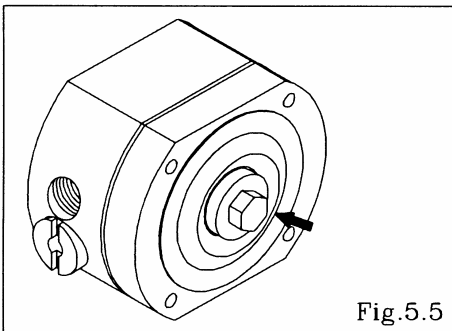

- Remove the center disk using the cap and disk remover. (special tool: Part No. 771132). (NDP-5) [Fig.5.5]
- Remove the center disk from one side.(NDP-15) [Fig.5.5]
- After the center disk (outside) has been removed, remove the diaphragm and the center disk (inside).
- Remove the center disk and center rod from the opposite side of the main body.

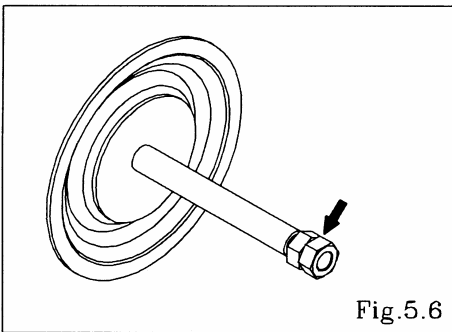

<NOTE>

- When the diaphragms are removed, the main body is separated 2 pieces. For easy work, leave bolts fastened temporarily before remove the diaphragms.
- Fix a double nut to one end of the center rod and take the diaphragm and center disk off the opposite end. [Fig.5.6]
- Be careful not to scratch or score the center rod.

5.2 Inspection

- Diaphragm
If the diaphragm is worn out or damaged, replace it.
New replace just one diaphragm.

Guideline of diaphragm life

| | | |
|--------|---------------|------------------|
| NDP-5 | PTFE | 30,000,000 cycle |
| NDP-15 | CR, NBR, PTFE | 10,000,000 cycle |
| | TPEE, TPO | 15,000,000 cycle |

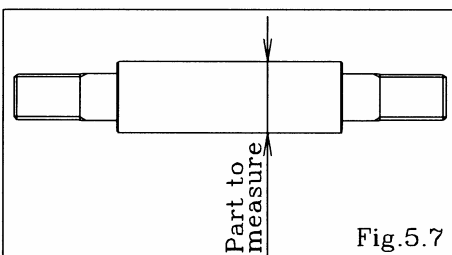

- Center rod [Fig.5.7]
Measure the diameter, and if it is outside the usable range, replace the rod.

Usable range of center rod

| | |
|--------|--------------------|
| NDP-5 | ø 9.95 ~ø 10.0 mm |
| NDP-15 | ø 13.96 ~ø 14.0 mm |

5.3 Installation

■ B□H, B□S, FPH, FPS types

For installation, see [9. Exploded View] on after p.11, and install in the reverse order of disassembly.

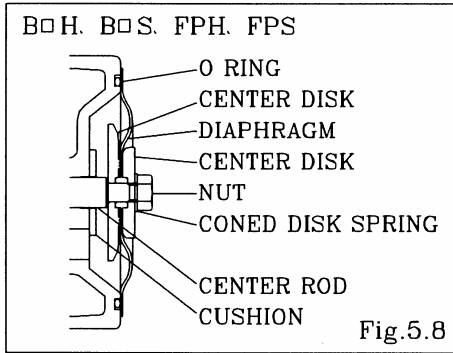

- Apply grease to the center rod, and insert it into the main body.
- Keep the convex side to the outside.
- Tighten the center disk using the open-end wrenches for the NDP-15FP□, FVS. (No coned disk springs and nuts are needed.)
- Tighten the out chamber temporarily at first.
- After installation of the out chambers on both sides, place the pump on a flat surface and stand the pump upright for further assembly.

| Tightening torque for center rod and out chamber | | |
|--|------------|-------------|
| | Center rod | Out chamber |
| NDP-5 | 7.5 N·m | |
| NDP-15 | 14 N·m | 12 N·m |

<NOTE>

- Make sure there is no dust on the seal surface in order to prevent seal damaged.
- Tighten the bolts that balance should be equal from both side on diagonal line with even torque.

■ B□C, B□N, B□T, FPC, FPN, F□T types

For installation, see [9. Exploded View] on after p. 11, and install in the reverse order of disassembly.

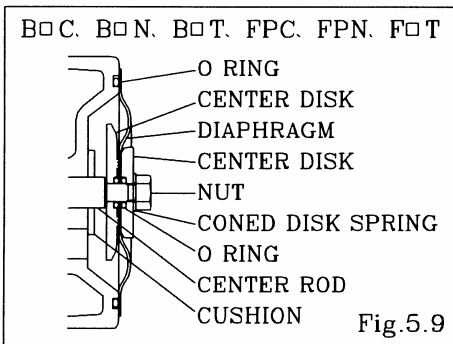

- Apply grease to the center rod, and insert it into the main body.
- Keep the marking "LIQUID" to liquid end for CR, NBR diaphragms.
- Keep the convex side to the outside for PTFE diaphragm. Install the O ring (cf. Fig.5.9).
- Tighten the center disk using the open-end wrenches
- After installation of the out chambers on both sides, place the pump on a flat surface and stand the pump upright for further assembly.

| Tightening torque for center rod and out chamber | | |
|--|------------|-------------|
| | Center rod | Out chamber |
| NDP-5 | 7.5 N·m | |
| NDP-15 | 14 N·m | 12 N·m |

< NOTE >

- Make sure there is no dust on the seal surface in order to prevent seal damaged.
- Replace the PTFE O ring by new one.
- Tighten the bolts that balance should be equal from both side on diagonal line with even torque.

6. Pilot valve Assembly, Guide and Bushing

6.1 Removal

■ NDP-5

See [9. Exploded View] on after p.11.

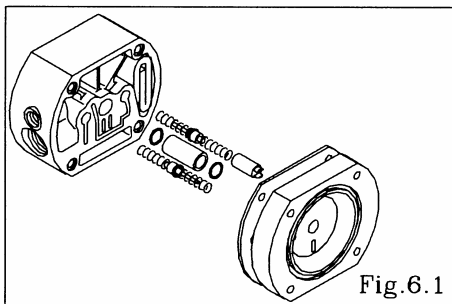

- Remove the diaphragm and center rod etc.(see [5.1 Removal] on p.5)
- Remove the main body. [Fig.6.1]
- Draw out the pilot valve assembly. [Fig.6.1]
- Remove the packing and bushing. [Fig.6.1]

■ NDP-15

See [9. Exploded View] on after p.11.

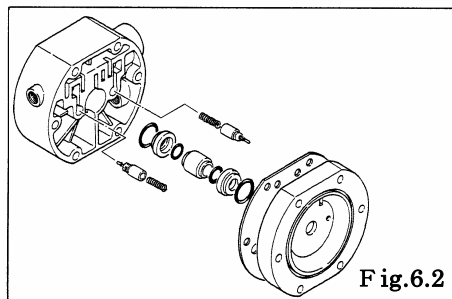

- Remove the diaphragm and center rod etc.(see [5.1 Removal] on p.5)
- Remove the body B. [Fig.6.2]
- Draw out the pilot valve assembly. [Fig.6.2]
- Remove the packing, bushing and guide. [Fig.6.2]

6.2 Inspection

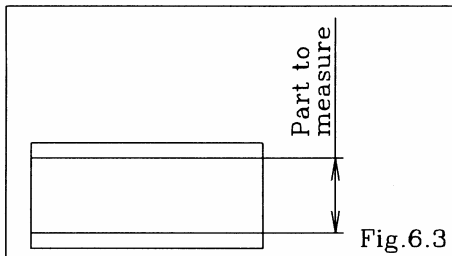

- Bushing (NDP-5) [Fig.6.3]
Measure the inside diameter, and if it is outside the usable range, replace the bushing.

Usable range of bushing
 $\varnothing 10.1 \sim \varnothing 10.3 \text{ mm}$

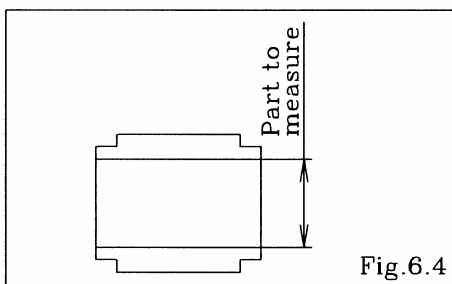

- Guide (NDP-15) [Fig.6.4]
Measure the inside diameter, and if it is outside the usable range, replace the guide.

Usable range of guide
 $\varnothing 14.1 \sim \varnothing 14.2 \text{ mm}$

- O ring, Packing
If the O ring is worn out or cracked, replace it.
- Pilot valve assembly
If the pilot valve is worn out or cracked, replace it.

6.3 Installation

For installation, see [9. Exploded View] on after p.11, and install in the reverse order of disassembly.

The correct direction of the V packing

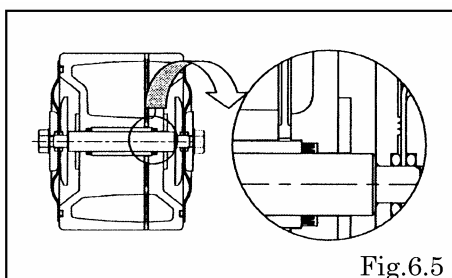

<NOTE>

- Make sure there is no dust on the seal surface and the seal is not damaged.
- Apply grease to packing.
- The open side of the V faces toward the diaphragm (air chamber).

7.C spool valve assembly and Sleeve assembly

7.1 Removal

See [9.Exploded View] on after p.11. (Fig. 7.1, 7.2 and 7.3 show the NDP-5 FAT.)

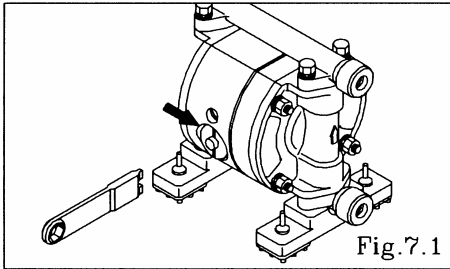

- Remove the cap using the cap and disk remover (special tool: Part No. 771132). [Fig.7.1]

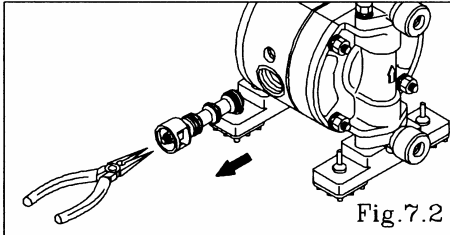

- Draw out the C spool valve assembly using the plier, and remove the seal ring from the C spool valve assembly. [Fig.7.2]

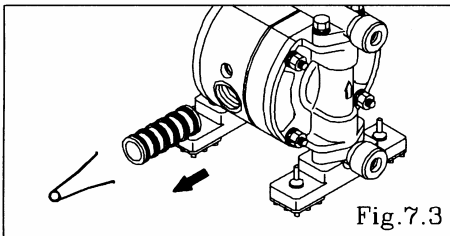

- Remove the sleeve using the sleeve remover (special tool: Part number 713148). [Fig.7.3]

7.2 Inspection

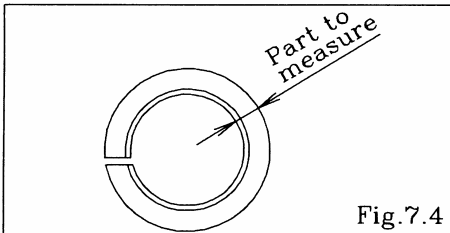

- C Spool valve Assembly
- Seal ring [Fig.7.4]

Measure the inside thick diameter, and if it is outside the usable range, replace the c spool valve assembly. If the seal ring is worn out or cracked, replace c spool Valve assembly.

Usable range of seal ring

| | |
|--------|----------------|
| NDP-5 | 1.40 ~ 1.45 mm |
| NDP-15 | 1.85 ~ 1.90 mm |

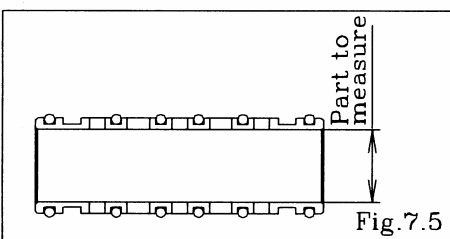

- Sleeve Assembly [Fig.7.5]

Measure the inside diameter, and if it is outside the usable range, replace the sleeve assembly.

Usable range of Sleeve

| | |
|--------|---------------------|
| NDP-5 | ∅ 9.5 ~ ∅ 9.55 mm |
| NDP-15 | ∅ 15.8 ~ ∅ 15.85 mm |

- O ring

If the O ring is worn out or cracked, replace it.

<NOTE>

- C Spool Valve Assembly and Sleeve Assembly must be Replaced complete set. Unable to replace individual component.

7.3 Installation

For installation, see [9. Exploded View] on after p.11, and install in the reverse order of disassembly.

<NOTE>

- Make sure there is no dust on the seal surface and it is not damaged.

8. Retightening of Tie rods

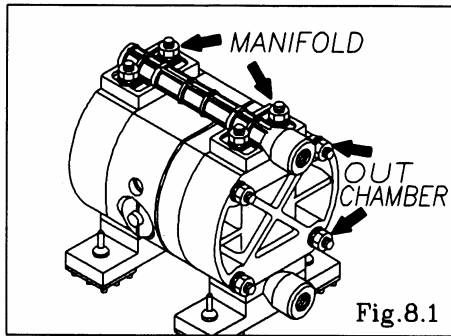

- The torque should be applied on the occasion of
 - (1) Right before the pump to use.
 - (2) There are any leaks of material on daily inspecting a pump.

| | | Retainer bolts from the out chamber | Retainer bolts from the manifold |
|--------|---------------|-------------------------------------|----------------------------------|
| NDP-5 | FPT, FVT, FDT | 7.5 N·m | 7.5 N·m |
| NDP-15 | FP□, FVT, FDT | 12 N·m | 12 N·m |

<NOTE>

- Tighten the bolts that balance should be equal from both side on diagonal line with even torque.
- Retighten the Out chamber and then the manifold in this order. [Fig.8.1]

9.Exploded View and Parts List

9.1 Exploded View

■NDP-5FAT, FST

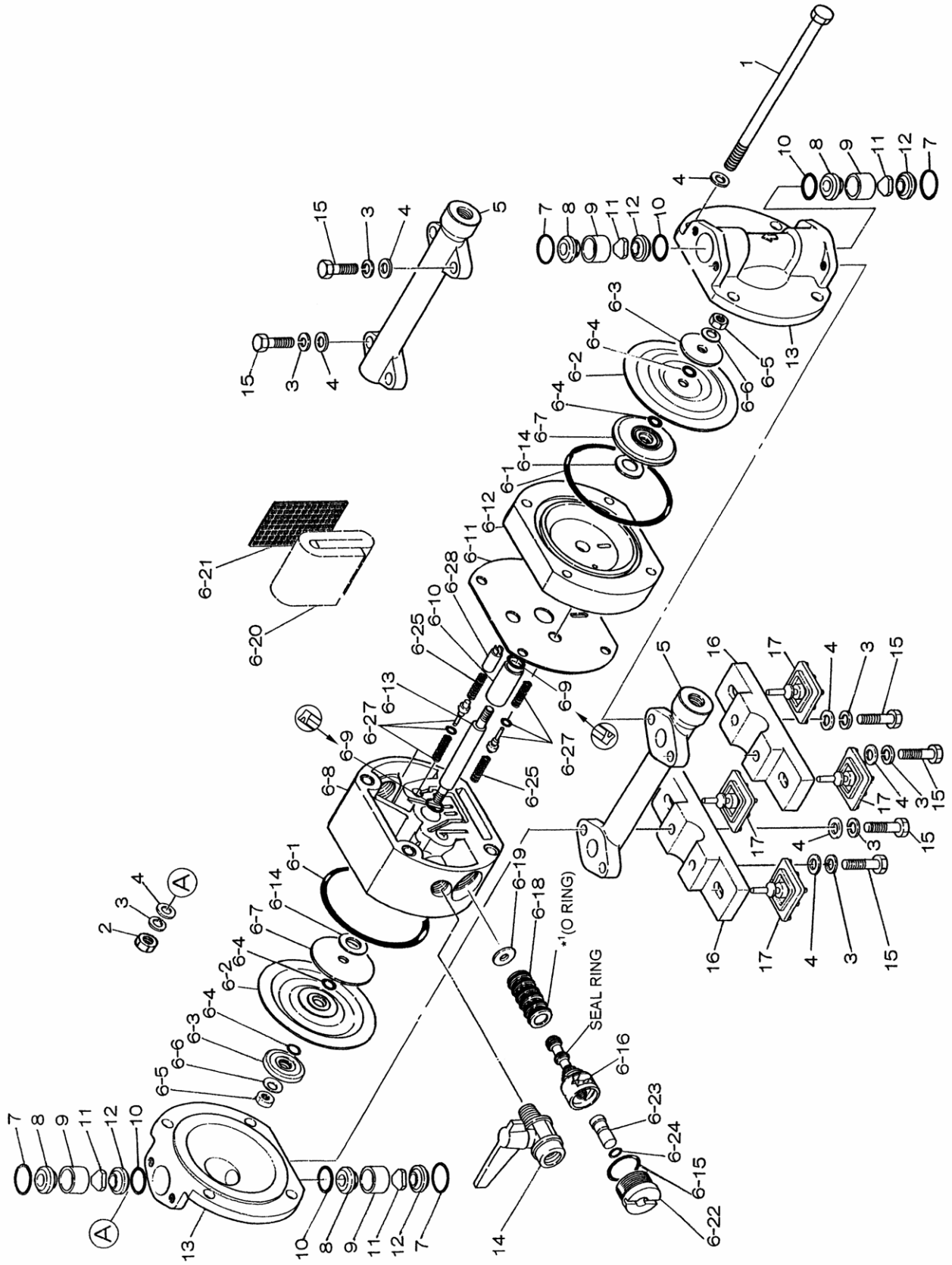

9.1 Parts List

■NDP-5AT, FST

| NO. | FAT | FST | DESCRIPTION | Q'TY | NOTE |
|-----|--------|--------|--------------------|------|----------|
| 1 | 682528 | ← | BOLT | 4 | M6x1x90 |
| 2 | 628010 | ← | NUT | 4 | M6x1 |
| 3 | 681855 | ← | SPRING LOCK WASHER | 12 | |
| 4 | 631328 | ← | PLAIN WASHER | 16 | |
| 5 | 709470 | ← | MANIFOLD | 2 | |
| | | 831274 | MANIFOLD ASSEMBLY | 2 | |
| 6 | 802047 | 802048 | BODY ASSEMBLY | 1 | |
| 7 | 643015 | ← | O RING | 4 | P16 PTFE |
| 8 | 709634 | ← | VALVE STOPPER | 4 | |
| 9 | 709635 | ← | VALVE GUIDE | 4 | |
| 10 | 771133 | ← | O RING | 4 | |
| 11 | 771152 | ← | FLAT VALVE | 4 | |
| 12 | 709637 | ← | VALVE SEAT | 4 | |
| 13 | 709469 | 709467 | OUT CHAMBER | 2 | |
| 14 | 682771 | ← | BALL VALVE | 1 | 1/4" |
| 15 | 621103 | ← | BOLT | 8 | M6x1x25 |
| 16 | 771101 | ← | PUMP BASE | 2 | |
| 17 | 771102 | ← | CUSHION | 4 | |
| 18 | 790910 | ← | NAME PLATE | 1 | |

NOTE 1)NO.18(NAME PLATE) IS NOT INDICATED IN EXPLODED VIEW

802047, 802048 BODY ASSEMBLY

| NO. | FAT | FST | DESCRIPTION | Q'TY | NOTE |
|------|--------|--------|------------------------|------|-------------------------|
| 6-1 | 640139 | ← | O RING | 2 | G70 NBR |
| 6-2 | 771093 | ← | DIAPHRAGM | 2 | |
| 6-3 | 709477 | 709476 | CENTER DISK | 2 | |
| 6-4 | 643003 | ← | O RING | 4 | P6 NBR |
| 6-5 | 683391 | ← | NUT | 2 | M6x1 |
| 6-6 | 684915 | ← | CONED DISK SPRING | 2 | |
| 6-7 | 709317 | ← | CENTER DISK | 2 | |
| 6-8 | 780000 | ← | BODY | 1 | |
| 6-9 | 685752 | ← | PACKING | 2 | |
| 6-10 | 771088 | ← | BUSHING | 1 | |
| 6-11 | 771980 | ← | GASKET | 1 | |
| 6-12 | 780001 | ← | BODY | 1 | |
| 6-13 | 709316 | ← | CENTER ROD | 1 | |
| 6-14 | 771239 | ← | CUSHION | 2 | |
| 6-15 | 640017 | ← | O RING | 1 | P20 NBR |
| 6-16 | 802386 | ← | C SPOOL VALVE ASSEMBLY | 1 | |
| 6-18 | 803214 | ← | SLEEVE ASSEMBLY | 1 | * ¹ (771097) |
| 6-19 | 771096 | ← | CUSHION | 1 | |
| 6-20 | 771465 | ← | SILENCER | 1 | |
| 6-21 | 771589 | ← | MESH | 1 | |
| 6-22 | 771100 | ← | CAP | 1 | |
| 6-23 | 771099 | ← | RESET BUTTON | 1 | |
| 6-24 | 640002 | ← | O RING | 1 | P5 NBR |
| 6-25 | 709319 | ← | SPRING | 2 | |
| 6-27 | 803510 | ← | PILOT VALVE ASSEMBLY | 2 | |
| 6-28 | 771095 | ← | STOPPER | 1 | |

NOTE)*1: PARTS NUMBER MENTIONED ON O RING FOR SLEEVE ASSEMBLY ONLY.

9.2 Exploded View

■ NDP-5FPT, FVT, FDT

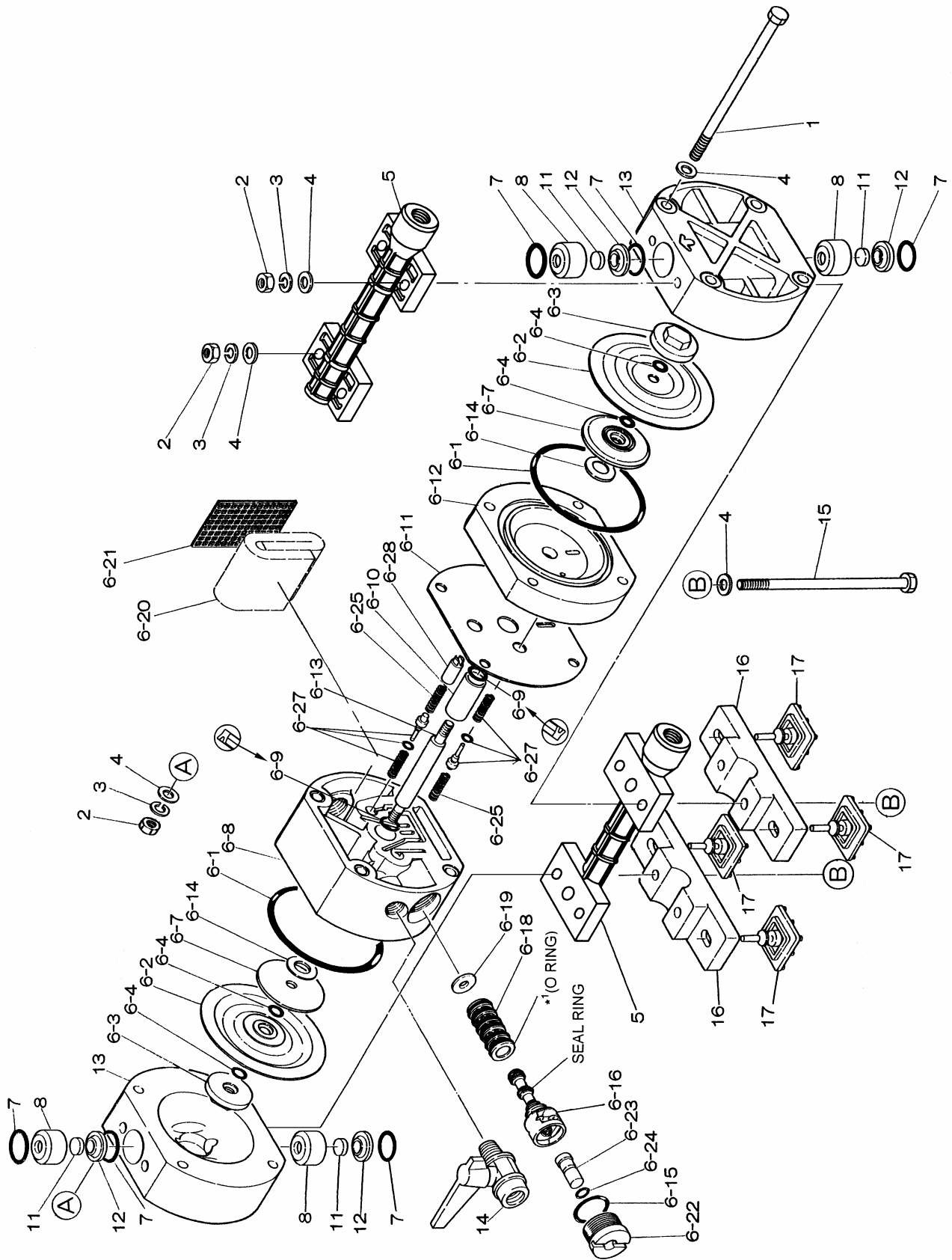

9.2 Parts List

■NDP-5FPT, FVT, FDT

| NO. | FPT | FVT | FDT | DESCRIPTION | Q'TY | NOTE |
|-----|--------|--------|--------|--------------------|------|----------|
| 1 | 682748 | ← | ← | BOLT | 4 | M6x1x140 |
| 2 | 628010 | ← | ← | NUT | 8 | M6x1 |
| 3 | 681855 | ← | ← | SPRING LOCK WASHER | 8 | |
| 4 | 631328 | ← | ← | PLAIN WASHER | 16 | |
| 5 | 780132 | 780054 | 780198 | MANIFOLD | 2 | |
| 6 | 802321 | 802849 | 804391 | BODY ASSEMBLY | 1 | |
| 7 | 643015 | ← | ← | O RING | 6 | P16 PTFE |
| 8 | 772655 | 771581 | 772712 | VALVE STOPPER | 4 | |
| 11 | 771094 | ← | ← | FLAT VALVE | 4 | |
| 12 | 772738 | 772735 | 772736 | VALVE SEAT | 4 | |
| 13 | 780231 | 780232 | 780233 | OUT CHAMBER | 2 | |
| 14 | 682771 | ← | ← | BALL VALVE | 1 | 1/4" |
| 15 | 682747 | ← | ← | BOLT | 4 | M6x1x125 |
| 16 | 771101 | 771648 | 772715 | PUMP BASE | 2 | |
| 17 | 771102 | ← | ← | CUSHION | 4 | |
| 18 | 790910 | ← | ← | NAME PLATE | 1 | |

NOTE 1)NO.18(NAME PLATE) IS NOT INDICATED IN EXPLODED VIEW

802321, 802849, 804391 BODY ASSEMBLY

| NO. | FPT | FVT | FDT | DESCRIPTION | Q'TY | NOTE |
|------|--------|--------|--------|------------------------|------|-------------------------|
| 6-1 | 640139 | ← | ← | O RING | 2 | G70 NBR |
| 6-2 | 771093 | ← | ← | DIAPHRAGM | 2 | |
| 6-3 | 771089 | 771579 | 772721 | CENTER DISK | 2 | |
| 6-4 | 643003 | ← | ← | O RING | 4 | P6 PTFE |
| 6-7 | 709317 | ← | ← | CENTER DISK | 2 | |
| 6-8 | 780000 | ← | ← | BODY | 1 | |
| 6-9 | 685752 | ← | ← | PACKING | 2 | |
| 6-10 | 771088 | ← | ← | BUSHING | 1 | |
| 6-11 | 771980 | ← | ← | GASKET | 1 | |
| 6-12 | 780001 | ← | ← | BODY | 1 | |
| 6-13 | 709316 | ← | ← | CENTER ROD | 1 | |
| 6-14 | 771239 | ← | ← | CUSHION | 2 | |
| 6-15 | 640017 | ← | ← | O RING | 1 | P20 NBR |
| 6-16 | 802386 | ← | ← | C SPOOL VALVE ASSEMBLY | 1 | |
| 6-18 | 803214 | ← | ← | SLEEVE ASSEMBLY | 1 | * ¹ (771097) |
| 6-19 | 771096 | ← | ← | CUSHION | 1 | |
| 6-20 | 771465 | ← | ← | SILENCER | 1 | |
| 6-21 | 771589 | ← | ← | MESH | 1 | |
| 6-22 | 771100 | ← | ← | CAP | 1 | |
| 6-23 | 771099 | ← | ← | RESET BUTTON | 1 | |
| 6-24 | 640002 | ← | ← | O RING | 1 | P5 NBR |
| 6-25 | 709319 | ← | ← | SPRING | 2 | |
| 6-27 | 803510 | ← | ← | PILOT VALVE ASSEMBLY | 2 | |
| 6-28 | 771095 | ← | ← | STOPPER | 1 | |

NOTE)*1: PARTS NUMBER MENTIONED ON O RING FOR SLEEVE ASSEMBLY ONLY.

9.3 Exploded View

■NDP-15BA□, BS□

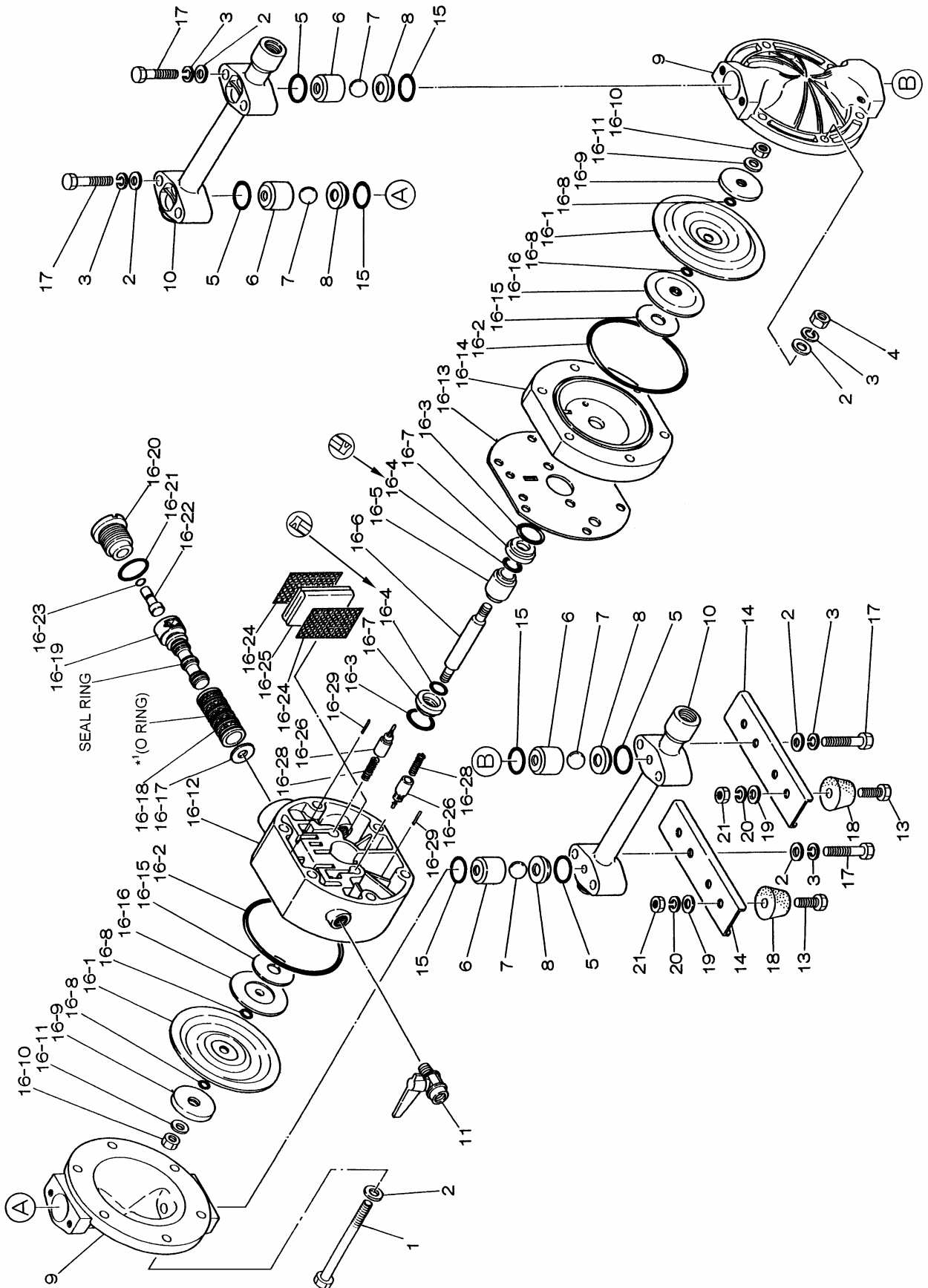

9.3 Parts List

■NDP-15BA□, BS□

| NO. | BA□ | BS□ | DESCRIPTION | Q'TY | NOTE |
|-----|---------------------------------|---------------------------------|--------------------|------|-------------|
| 1 | 683171 | | BOLT | 6 | M8x1.25x110 |
| | | 683224 | BOLT | 6 | M8x1.25x105 |
| 2 | 631329 | ← | PLAIN WASHER | 20 | |
| 3 | 681300 | ← | SPRING LOCK WASHER | 14 | |
| 4 | 628012 | ← | NUT | 6 | M8x1.25 |
| 5 | Tab.1 | ← | O RING | 4 | |
| 6 | 771523 | 711502 | VALVE STOPPER | 4 | |
| 7 | Tab.2 | ← | BALL | 4 | |
| 8 | 711227 | 711382 | VALVE SEAT | 4 | |
| 9 | 711226 | 711380 | OUT CHAMBER | 2 | |
| 10 | 802707 | | MANIFOLD ASSEMBLY | 2 | |
| | | 711501 | MANIFOLD | 2 | |
| 11 | 682771 | ← | BALL VALVE | 1 | 1/4" |
| 12 | 790910 | ← | NAME PLATE | 1 | |
| 13 | 621102 | ← | BOLT | 4 | M6x1x22 |
| 14 | 711405 | ← | PUMP BASE | 2 | |
| 15 | Tab.3 | ← | O RING | 4 | |
| 16 | Tab.4 | ← | BODY ASSEMBLY | 1 | |
| 17 | 682727 | | BOLT | 8 | M8x1.25x60 |
| | | 621155 | BOLT | 8 | M8x1.25x40 |
| 18 | 771123 | ← | CUSHION | 4 | |
| 19 | 631328 | ← | PLAIN WASHER | 4 | |
| 20 | 681855 | ← | SPRING LOCK WASHER | 4 | |
| 21 | 628010 | ← | NUT | 4 | M6x1 |

Tab.1 O RING (P26)

| TYPE | BA/BS□ | MATERIAL |
|-------|--------|----------|
| B□C | 640025 | NBR |
| B□N | 640025 | NBR |
| B□T | 643025 | PTFE |
| B□H | 640025 | NBR |
| B□S | 684114 | EPDM |
| B□H/T | 640025 | NBR |

Tab.2 BALL

| TYPE | BA/BS□ | MATERIAL |
|-------|--------|----------|
| B□C | 771526 | CR |
| B□N | 771525 | NBR |
| B□T | 771524 | PTFE |
| B□H | 771525 | NBR |
| B□S | 771979 | EPDM |
| B□H/T | 771524 | PTFE |

Tab.3 O RING (G25)

| TYPE | BA/BS□ | MATERIAL |
|-------|--------|----------|
| B□C | 640130 | NBR |
| B□N | 640130 | NBR |
| B□T | 643130 | PTFE |
| B□H | 640130 | NBR |
| B□S | 684113 | EPDM |
| B□H/T | 640130 | NBR |

Tab.4 BODY ASSEMBLY

| TYPE | BA□ | BS□ |
|-------|--------|--------|
| B□C | 802993 | 802997 |
| B□N | 802994 | 802998 |
| B□T | 802992 | 802996 |
| B□H | 802995 | 802999 |
| B□S | 803502 | 803503 |
| B□H/T | 802995 | 802999 |

NOTE 1)NO.12(NAME PLATE) IS NOT INDICATED IN EXPLODED VIEW

9.4 Exploded View

■NDP-15FP□, FV□, FDT

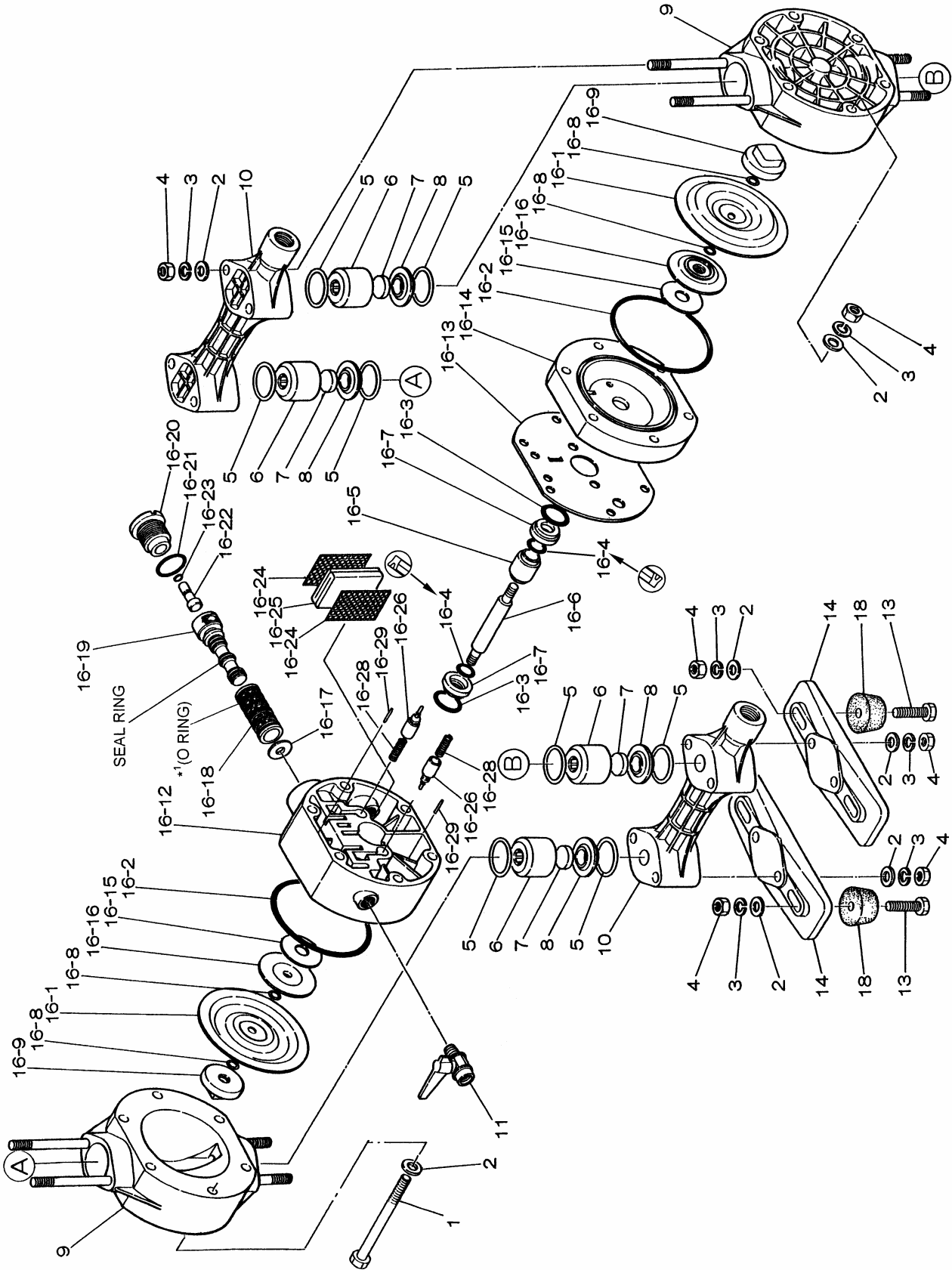

9.4 Parts List

■NDP-15FP□, FV□, FDT

| NO. | FP□ | FV□ | FDT | DESCRIPTION | Q'TY | NOTE |
|-----|--------|--------|--------|--------------------|------|-------------|
| 1 | 684310 | ←←← | ←←← | BOLT | 6 | M8x1.25x185 |
| 2 | 631329 | ←←← | ←←← | PLAIN WASHER | 24 | |
| 3 | 681300 | ←←← | ←←← | SPRING LOCK WASHER | 18 | |
| 4 | 628012 | ←←← | ←←← | NUT | 18 | M8x1.25 |
| 5 | Tab.1 | 643027 | ←←← | O RING | 8 | P29 |
| 6 | 771341 | 771632 | 772718 | VALVE STOPPER | 4 | |
| 7 | 771340 | 771762 | 771340 | FLAT VALVE | 4 | |
| 8 | 771345 | 771633 | 772719 | VALVE SEAT | 4 | |
| 9 | 780119 | 780120 | 780199 | OUT CHAMBER | 2 | |
| 10 | 780026 | 780055 | 780200 | MANIFOLD | 2 | |
| 11 | 682771 | ←←← | ←←← | BALL VALVE | 1 | 1/4" |
| 12 | 790910 | ←←← | ←←← | NAME PLATE | 1 | |
| 13 | 621153 | ←←← | ←←← | BOLT | 4 | M8x1.25x35 |
| 14 | 771352 | 771635 | 772720 | PUMP BASE | 2 | |
| 16 | Tab.2 | ←←← | 804392 | BODY ASSEMBLY | 1 | |
| 18 | 770551 | ←←← | 770551 | CUSHION | 4 | |

NOTE 1)NO.12(NAME PLATE) IS NOT INDICATED IN EXPLODED VIEW

Tab.1 O RING(P29)

| TYPE | FP□ | MATERIAL |
|------|--------|----------|
| FPC | 640027 | NBR |
| FPN | 640027 | NBR |
| FPT | 643027 | PTFE |
| FPH | 640027 | NBR |
| FPS | 684115 | EPDM |

Tab.2 BODY ASSEMBLY

| TYPE | FP□ |
|------|--------|
| FPC | 802989 |
| FPN | 802991 |
| FPT | 802988 |
| FPH | 802990 |
| FPS | 803504 |

9.5 Parts List

■NDP-15 BODY ASSEMBLY

BODY ASSEMBLY

| NO. | BA□ | BS□ | FP□ | FV□ | FDT | DESCRIPTION | Q'TY | NOTE |
|-------|--|--|--|------------------|--------|------------------------|------|------------|
| | 802992 802993 802994 802995 803502 | 802996 802997 802998 802999 803503 | 802988 802989 802990 802991 803504 | 803003 803565 | 804392 | | | |
| 16-1 | Tab.1 | ← | Tab.3 | ← | ← | DIAPHRAGM | 2 | |
| 16-2 | 640144 | ← | 640144 | ← | ← | O RING | 2 | G95 NBR |
| 16-3 | 640020 | ← | 640020 | ← | ← | O RING | 2 | P22A NBR |
| 16-4 | 684284 | ← | 684284 | ← | ← | PACKING | 2 | |
| 16-5 | 771337 | ← | 771337 | ← | ← | GUIDE | 1 | |
| 16-6 | 710578 | ← | 710578 | ← | ← | CENTER ROD | 1 | |
| 16-7 | 771336 | ← | 771336 | ← | ← | BUSHING | 2 | |
| 16-8 | Tab.2 | ← | Tab.4 | ← | ← | O RING | 4 | |
| 16-9 | 708770 | 708506 | 770968 | 771631 | 772722 | CENTER DISK | 2 | |
| 16-10 | 681849 | ← | | | | NUT | 2 | M8x1.25 |
| 16-11 | 684916 | ← | | | | CONED DISK SPRING | 2 | |
| 16-12 | 780028 | ← | 780028 | ← | ← | BODY | 1 | |
| 16-13 | 771347 | ← | 771347 | ← | ← | GASKET | 1 | |
| 16-14 | 780030 | ← | 780030 | ← | ← | BODY | 1 | |
| 16-15 | 771342 | ← | 771342 | ← | ← | CUSHION | 2 | |
| 16-16 | 771344 | ← | 771344 | ← | ← | CENTER DISK | 2 | |
| 16-17 | 771483 | ← | 771483 | ← | ← | CUSHION | 1 | |
| 16-18 | 804249 | ← | 804249 | ← | ← | SLEEVE ASSEMBLY | 1 | *1(683123) |
| 16-19 | 802835 | ← | 802835 | ← | ← | C SPOOL VALVE ASSEMBLY | 1 | |
| 16-20 | 771695 | ← | 771695 | ← | ← | CAP | 1 | |
| 16-21 | 640022 | ← | 640022 | ← | ← | O RING | 1 | P24 NBR |
| 16-22 | 771350 | ← | 771350 | ← | ← | RESET BUTTON | 1 | |
| 16-23 | 640002 | ← | 640002 | ← | ← | O RING | 1 | P5 NBR |
| 16-24 | 771589 | ← | 771589 | ← | ← | MESH | 2 | |
| 16-25 | 771465 | ← | 771465 | ← | ← | SILENCER | 1 | |
| 16-26 | 832141 | ← | 832141 | ← | ← | PILOT VALVE ASSEMBLY | 2 | |
| 16-28 | 710577 | ← | 710577 | ← | ← | SPRING | 2 | |
| 16-29 | 632752 | ← | 632752 | ← | ← | SPRING PIN | 2 | φ 2x8 |

NOTE)*1: PARTS NUMBER MENTIONED ON O RING FOR SLEEVE ASSEMBLY ONLY.

Tab.1 DIAPHRAGM

| TYPE | BA/BS□ | MATERIAL |
|-------|--------|----------|
| B□C | 770971 | CR |
| B□N | 770973 | NBR |
| B□T | 770933 | PTFE |
| B□H | 771372 | TPEE |
| B□S | 771972 | TPO |
| B□H/T | 771372 | TPEE |

Tab.2 O RING(P8)

| TYPE | BA/BS□ | MATERIAL |
|-------|--------|----------|
| B□C | 640005 | NBR |
| B□N | 640005 | NBR |
| B□T | 643005 | PTFE |
| B□H | | |
| B□S | | |
| B□H/T | | |

Tab.3 DIAPHRAGM

| TYPE | FP□ | FV□ | MATERIAL |
|------|--------|-----|----------|
| F□C | 770971 | | CR |
| F□N | 770973 | | NBR |
| F□T | 770933 | ← | PTFE |
| F□H | 771372 | | TPEE |
| F□S | 771972 | ← | TPO |

Tab.4 O RING(P8)

| TYPE | FP□ | FV□ | MATERIAL |
|------|--------|-----|----------|
| F□C | 640005 | | NBR |
| F□N | 640005 | | NBR |
| F□T | 643005 | ← | PTFE |
| F□H | | | |
| F□S | | | |

Manufactured by

YAMADA CORPORATION

INTERNATIONAL DEPARTMENT

No.1-3, 1-Chome, Minami-Magome, Ohta-Ku, Tokyo, 143-8504, Japan

PHONE : +81-(0)3-3777-0241

FAX : +81-(0)3-3777-0584

200902 NDP183M