

MAINTENANCE MANUAL

YAMADA AIR-OPERATED DIAPHRAGM PUMPS

DP-10Fs

DP-20Fs

WARNING



- For safety's sake, be sure to read this maintenance manual thoroughly before starting maintenance for this product. After reading the manual, keep it in an easy-to-access place so that the user may refer to it whenever necessary.

This maintenance manual describes the items required for maintenance of the Yamada DP-F's series Diaphragm Pumps.

This document is based on the products that are manufactured in March 2011. Note that its contents are subject to change as a result of specification changes to be made in future.

- Warnings and Cautions

To use this product safely, be sure to observe the contents of the following description. In this manual, warnings and cautions are indicated by using symbols. These symbols are intended to prevent death or serious injury that may be caused to the operator or those who are around the product and damage that may be caused to the articles that are around the product, as well as to use the product safely and correctly. Each symbol is indicated and has a meaning as shown below. Read the description with a good understanding of its contents.



WARNING: This indicates the existence of potential hazard which, if not avoided, will result in death or serious injury.



CAUTION: This indicates the existence of potential hazard which, if not avoided, may result in bodily injury or in physical damage.

To indicate the contents of danger and damage, the following symbols are used together with the above indications.



This symbol indicates an act that is prohibited (prohibition). The concrete contents of prohibition are indicated by the side of the indication.



This symbol indicates the contents that must be observed. The concrete contents of observance are indicated by the side of the indication.

WARNING



- Before starting the maintenance work, shut off the supply air and clean the pump. If air pressure or residual liquid remains in the pump, damage or explosion may be caused to the product or serious injury or death may be caused if it sticks on the eyes or skin or inhaled or swallowed. (For cleaning the pump, refer to Chapter 6 of the Operation Manual.)
- When replacing parts, be sure to use the genuine parts or equivalents. Using parts other than these parts may result in a fault.
(Refer to Exploded View and Reminder to order correct item on the separate sheets.)

CAUTION



- When it is indicated that dedicated tools should be used, be sure to use these dedicated tools, otherwise the pump may be damaged.
- Check the weight of the pump by referring to 10.1 Main Specifications in the operation manual and take extreme care when lifting it.

Table of Contents

- Warnings and Cautions	
- Table of Contents	
1. Principle of Operation	1
2. Tool and Others Required	
2.1 General Tools	1
2.2 Dedicated Tools.....	1
2.3 Others	2
3. Ordering Replacement parts	2
4. Ball and Valve Seats	
4.1 Removal	2
4.2 Inspection	3
4.3 Installation	3
5. Valve Body and C Spool Valve Assembly	
5.1 Removal	4
5.2 Inspection	5
5.3 Installation	6
6. Diaphragm, Center Rod and Bush	
6.1 Removal	7
6.2 Inspection	8
6.3 Installation	9
7. Pilot Valves, Valve Seats and Spring	
7.1 Removal	10
7.2 Inspection	10
7.3 Installation	10
8. Retightening of Tie rods	11
9. Instructions for applying lubrication	11

1. Principles of operation

There are two diaphragms fixed to the center rod, one at each end. When compressed air is supplied to air chamber “b” (right side, see Fig.1.1), the center rod moves to the right, the material in material chamber “B” is pushed out, and at the same time material is sucked into material chamber “A”. When the center rod is moved full-stroke to the right, the air switch valve is switched, compressed air is sent to air chamber “a” (left side, see Fig.1.2), and the center rod moves to the left. The material in material chamber “A” is pushed out, and at the same time material is sucked into material chamber “B”. Through repetition of this operation, material is repeatedly taken in and discharged out.

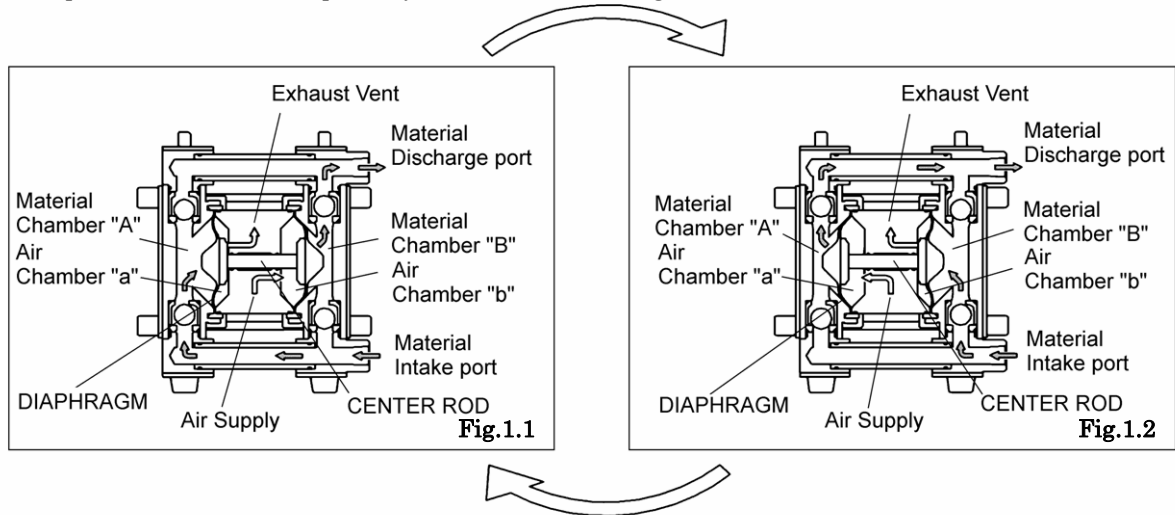

2. Tool and Others Required

2.1 General Tools

- Socket wrenches 10 mm, 17 mm
- Open-end wrenches 10 mm, 17 mm
- PLYER
- Snap ring pLYER

2.2 Dedicated Tools

- ①Pilot valve remover (optional)
 Purpose: Removing the pilot valve and cap
 Part No.: 712606

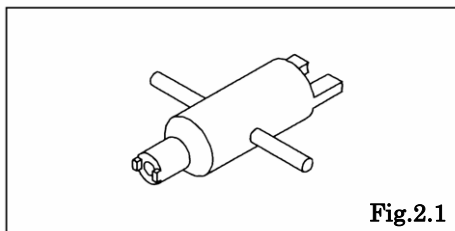

- ②Sleeve remover (optional)
 Purpose: Removing a sleeve
 Part No.: 713148

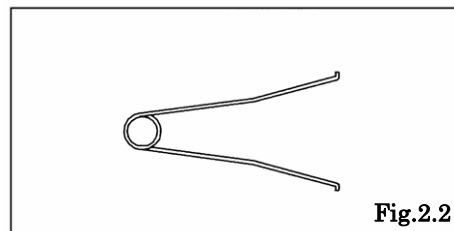

- ③Ring remover (optional)
 Purpose: Removing a ring
 Part No.: 832802 (for DP-10Fs)
 Part No.: 832803 (for DP-20Fs)

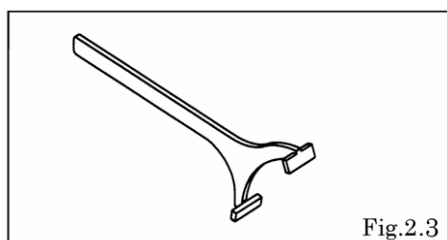

2.3 Others

- Assembly lubricating oil(oil) Solvay Solexis K.K. FOMBLIN Y25/A or equivalent
- Assembly lubricating oil (grease) Solvay Solexis K.K. FOMBLIN grease AR555 or equivalent
- Nuts M12×1.75 (DP-10Fs)、M14×1.5 (DP-20Fs)

3. Ordering Replacement parts

For accurate and speedy shipment of parts, be sure to order the right parts for your model to distributor. Indicate the part numbers, descriptions, and quantities.

4. Ball and Valve Seats

4.1 Removal

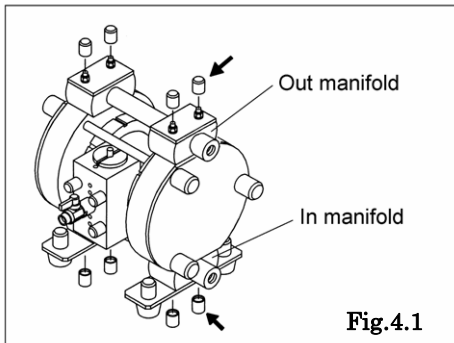

- Remove the 8 caps (4 caps on the up and down sides respectively) from the both sides of the upright tie rod. [Fig.4.1]
- Remove the 4 retainer nuts from the upper side of the upright tie rods, and then remove the reinforcement plate, out manifold, and sleeve. [Fig.4.1]
- When you remove the 8 retainer nuts (4 retainer nuts on the up and down sides respectively) from the both sides of the upright tie rod, the in manifold is removed from the main body also. [Fig.4.1]

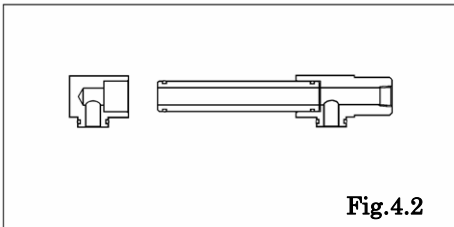

<NOTE>

- Since the manifold is designed to be disassembled easily, be careful to remove it from the main body so that you cannot happen to drop any of its parts. [Fig.4.2]

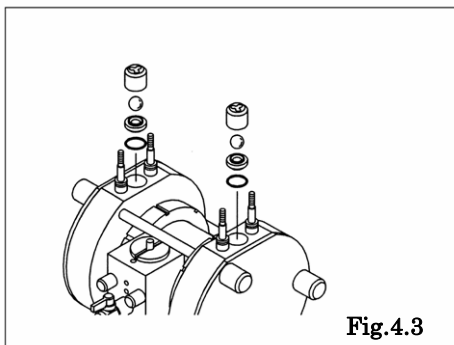

- Remove the valve stopper, ball, valve seat and O ring. [Fig.4.3]

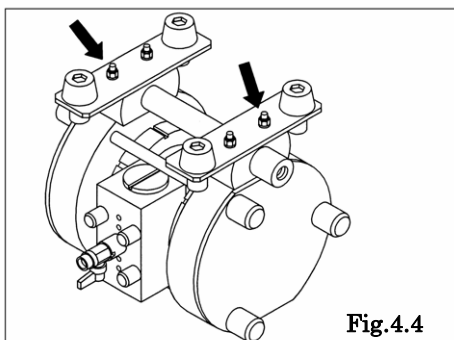

- Turn over the main body assembly. [Fig.4.4]
- Pull out the four upright tie rods, and then remove the base and in manifold. [Fig.4.4]

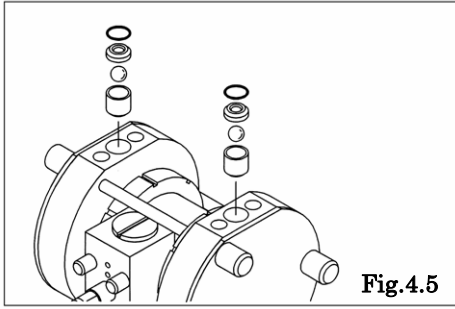

Fig.4.5

- Remove the O ring, valve seat, ball and valve stopper. [Fig.4.5]

4.2 Inspection

■ Ball Valves

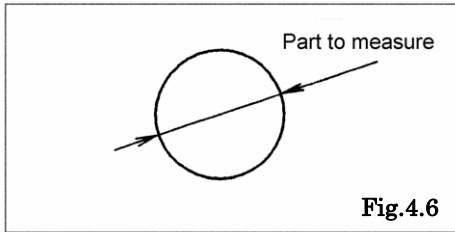

Fig.4.6

- Ball [Fig.4.6]
Measure the outside diameter, and if it is out of the allowable range, replace the ball with a new one.

Allowable range of the ball

DP-10Fs	Sφ 14.3 ~ Sφ 16.3 mm
DP-20Fs	Sφ 24.3 ~ Sφ 27.8 mm

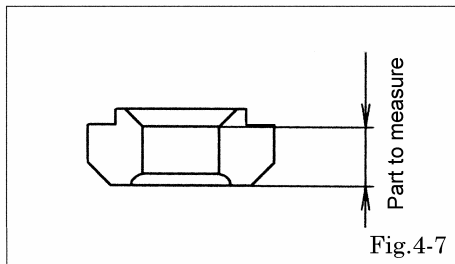

Fig.4-7

- Valve seat [Fig.4-7]
Measures the dimension shown on the left figure, and if it is out of the allowable range, replace the valve seat with a new one.

Allowable range of the valve seat

DP-10Fs	4.6 ~ 7.8 mm
DP-20Fs	4.8 ~ 8.2 mm

4.3 Installation

For installation, see [Exploded View] on the separate sheet and install in the reverse order of disassembly.

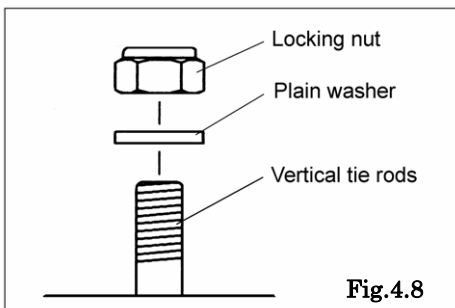

Fig.4.8

Tightening torque for vertical tie rod

DP-10Fs	2 N·m
DP-20Fs	

<NOTE>

- Make sure that there is not any dust on the seal surface and that any sealed part cannot be damaged.
- Replace the locking nut with a new one regardless of its condition. [Fig.4.8]
- Replace the PTEE or FFKM O ring with a new one regardless of its condition.
- Retighten the tie rods immediately before starting the pump. (See Section [8. Retightening the Tie Rods])

5. Valve Body and C Spool Valve Assembly

5.1 Removal

■ Valve body assembly

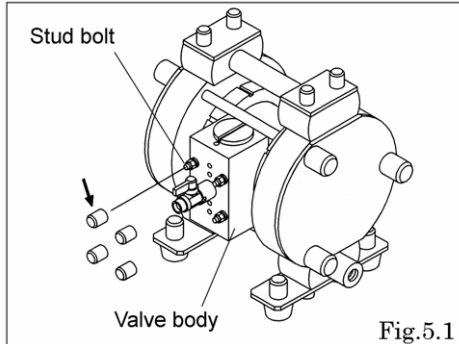

- Remove the 4 caps from the stud bolts. [Fig.5.1]
- Remove the 4 retainer nuts from the valve body, and then the valve body itself. [Fig.5.1]

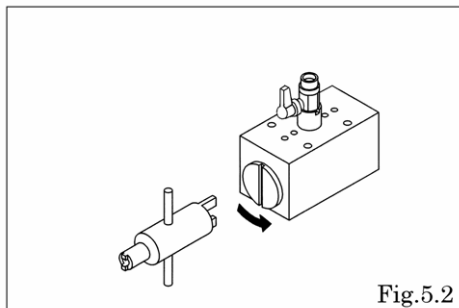

- Use the dedicated tool ① (pilot valve remover) to remove the caps located on the both sides of the valve body. [Fig.5.2]

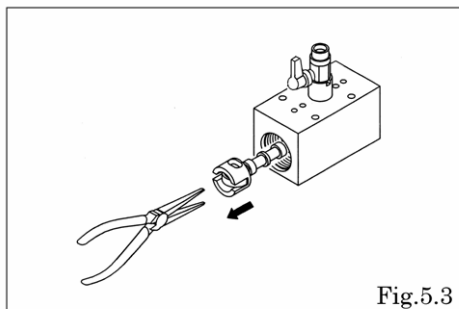

- Use a pleyer to pull out the C spool valve assembly. [Fig.5.3]

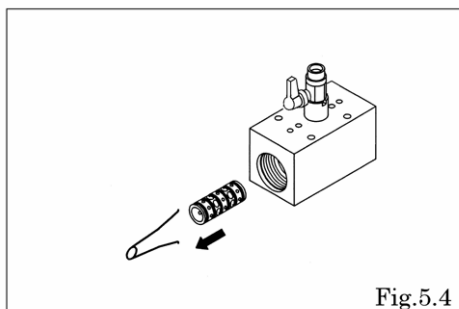

- Use the dedicated tool ② (sleeve remover) to remove the sleeve from the valve body. [Fig.5.4]

■ Disassembling of the C Spool Valve

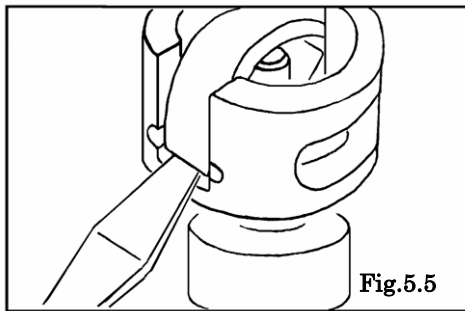

- Use a flat-blade screwdriver to raise the outside of the C spring so that the outside can be opened, and remove the C spring. [Fig.5.5 and 5.6]

<NOTE>

- When you remove the C spring, the arm is removed also.

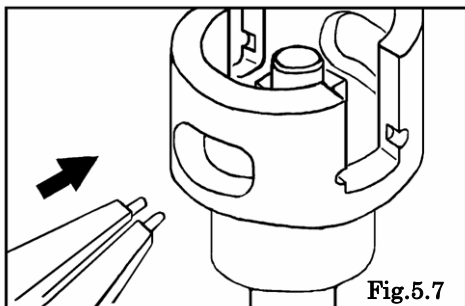
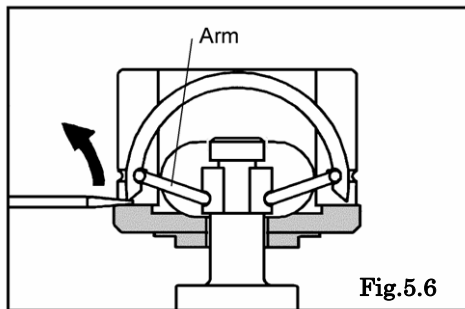

- Use the snap ring plier to remove the interlocking bush from the spool while opening and pushing the groove of the interlocking bush. [Fig.5.7 and 5.8]

<NOTE>

- Do not exert any excessive force to the spool.
- Do not open the groove of the interlocking bush more widely than it has to.
- When you remove the interlocking bush, the spring retaining cushion is removed also.

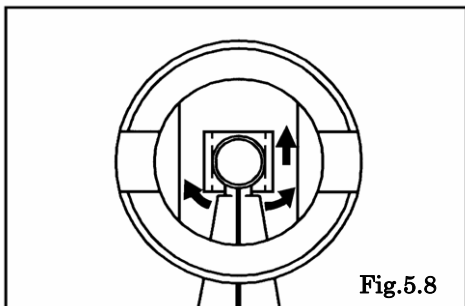

5.2 Inspection

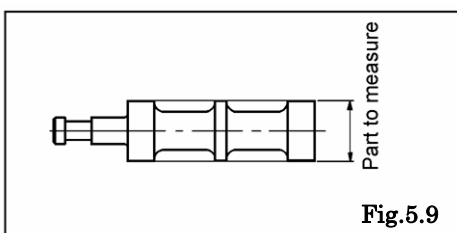

- Spool [Fig.5.9]
Measure the outside diameter, and if it is out of the allowable range, replace the spool with a new one.

Allowable range of the Spool

DP-10Fs/P/H, DP-20Fs/P/H	ϕ 15.73 ~ ϕ 15.80 mm
DP-10Fs/C/H, DP-20Fs/C/H	ϕ 15.77 ~ ϕ 15.80 mm

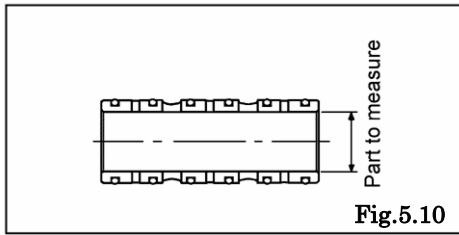

Fig.5.10

- Sleeve [Fig.5.10]
Measure the inside diameter, and if it is out of the allowable range, replace the sleeve with a new one. If the sleeve is cracked or damaged, replace it.

Allowable range of the Sleeve

DP-10Fs/P/H, DP-20Fs/P/H	$\phi 15.80 \sim \phi 15.86$ mm
DP-10Fs/C/H, DP-20Fs/C/H	$\phi 15.80 \sim \phi 15.82$ mm

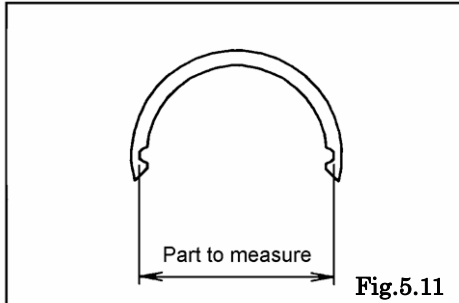

Fig.5.11

- O rings [Fig.5.10]
If the O ring is worn out or cracked, replace it with a new one.

<NOTE>

- Be sure to replace the spool and sleeve together as a complete set.

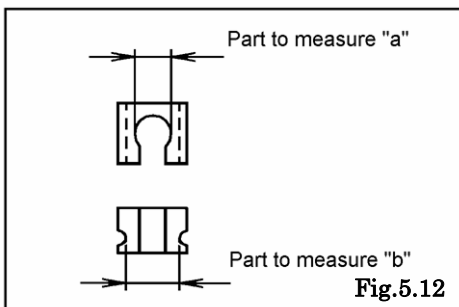

Fig.5.12

- C spring [Fig.5.11]
Measure the dimension shown on the left figure, and if it is out of the allowable range, replace the C spring.

Allowable range of the C spring

DP-10Fs	25.9 ~ 26.5 mm
DP-20Fs	

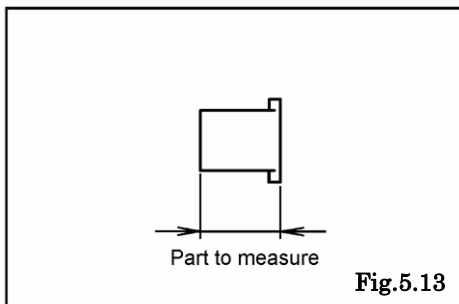

Fig.5.13

- Interlocking bush [Fig.5.12]
Measure the dimension shown on the left figure, and if it is out of the allowable range, replace the interlocking bush with a new one.

Usable range of Interlocking bush

Part to measure "a"	4.8 ~ 5.0 mm
Part to measure "b"	6.8 ~ 7.1 mm

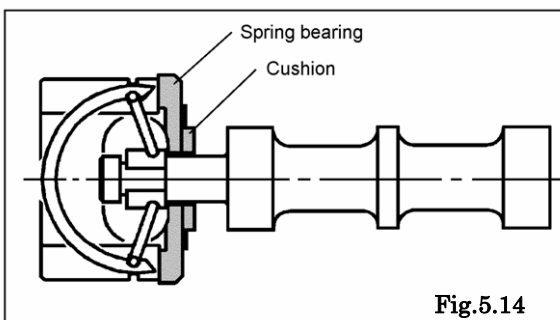

Fig.5.14

- Arm [Fig.5.13]
Measure the dimension shown on the left figure, and if it is out of the allowable range, replace the arm with a new one.

Usable range of Arm

DP-10Fs	10.5 ~ 10.9 mm
DP-20Fs	

- Spring bearing [Fig.5.14]
If the spring bearing is worn out or cracked, replace it with a new one.
- Cushion [Fig.5.14]
If the cushion is worn out or cracked, replace it with a new one.

5.3 Installation

For installation, see [Exploded View] on the separate sheet and install in the reverse order of disassembly.

Tightening torque of the valve body assembly attaching bolts

DP-10Fs	2 N·m
DP-20Fs	

<NOTE>

- Make sure there is no dust on the seal surface and the seal is not damaged.
- Be sure to fix the caps on both edges of the valve body until they reach the end face of the valve body.

6. Diaphragm, Center Rod and Bush

6.1 Removal

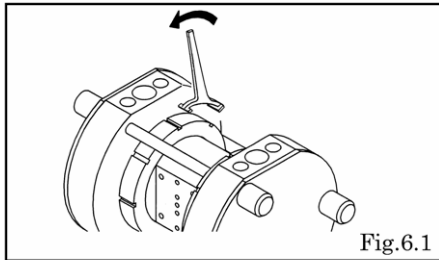

- Remove the ball, valve seat, and valve stopper See Section ([4.1 Removal])
- Use the dedicated tool ③ (ring remover) to loosen the both rings until the screws are removed. [Fig.6.1]

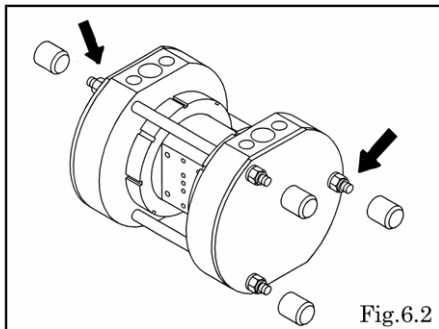

- Remove the 6 caps from the both sides of the horizontal tie rods. [Fig.6.2]
- Remove the 6 retainer nuts from the both sides of the horizontal tie rods, and then remove the reinforcements plate and out chamber. [Fig.6.2]

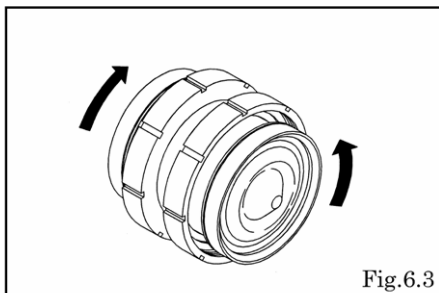

- While fixing one diaphragm, turn another diaphragm until it is removed. [Fig.6.3]
- After one diaphragm is removed, remove another diaphragm and center rod from the body.

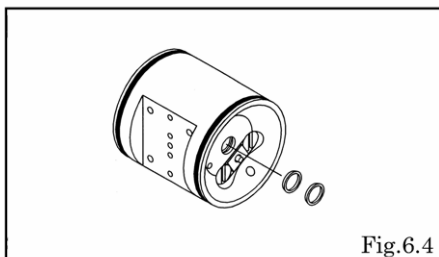

- Remove the packing, wiper the body. [Fig.6.4]

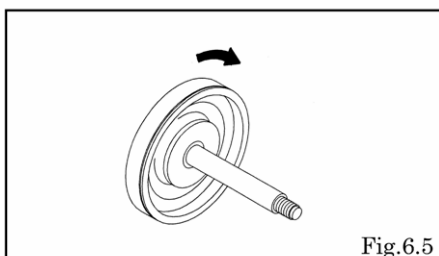

- While fixing the middle section of the center rod, turn the diaphragm until it is removed. [Fig.6.5]
If necessary, attach a double nut to the screw to fix the center rod.

<NOTE>

- Be careful not to damage the center rod.
- If you use a double nut, be careful not damage the screw.

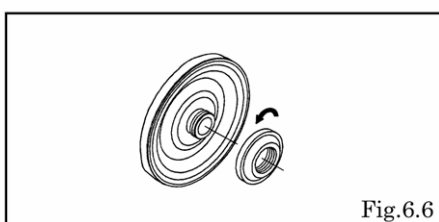

- Fix the diaphragm and turn the bush to remove it. [Fig.6.6]

6.2 Inspection

- Diaphragm
If the diaphragm is worn out or damaged, replace it with a new one.

Guideline of diaphragm life
(when used with clean water at room temperature)

DP-10Fs	12,000,000 cycle
DP-20Fs	6,000,000 cycle

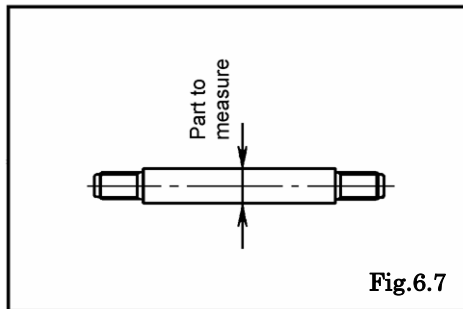

Fig.6.7

- Center rod [Fig.6-7]
Measure the diameter, and if it is out of the allowable range, replace the center rod with a new one.

Allowable range

DP-10Fs	$\phi 15.92 \sim \phi 15.98$ mm
DP-20Fs	$\phi 17.92 \sim \phi 17.98$ mm

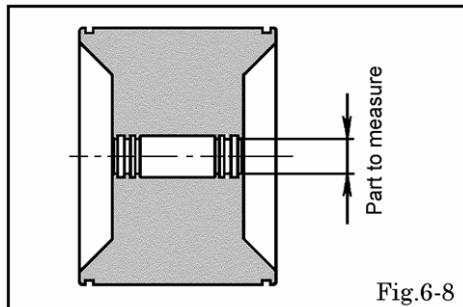

Fig.6-8

- Body [Fig.6.8]
Measure the inside diameter, and if it is out of the allowable range, replace the sleeve with a new one.

Allowable range

DP-10Fs	$\phi 16.03 \sim \phi 16.11$ mm
DP-20Fs	$\phi 18.03 \sim \phi 18.11$ mm

- Packing, Wiper
If the packing is worn out or damaged, replace it with a new one.

6.3 Installation

For installation, see [Exploded View] on the separate sheet and install in the reverse order of disassembly.

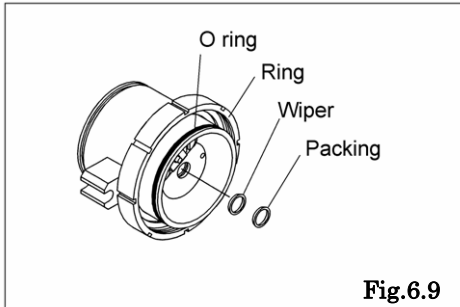

- Dab lubricant onto the wiper and install it into the pump body. [Fig.6.9]
- Apply lubricant to the packing and install it into the pump body. [Fig.6.9]
(Refer to Page 11 instruction for applying lubrication)
- Attach the ring and O ring onto one side. [Fig.6.9]

<NOTE>

- Be sure to attach the ring prior to the O ring.

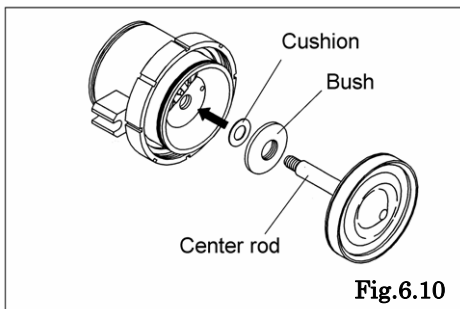

- Attach the bush to the diaphragm and attach the cushion to the center rod, and insert these parts into the body. [Fig.6.10]

<NOTE>

- Be sure to insert the diaphragm into the body until it reaches the end face of the body securely.

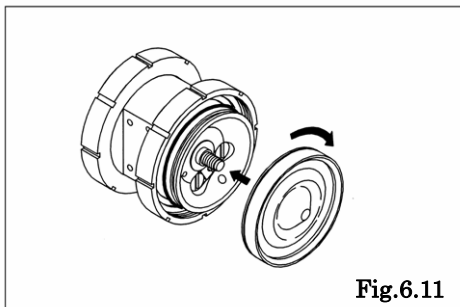

- Attach the ring, O ring and cushion to another side of the body. Be sure to attach the O ring over the groove. [Fig.6.11]
- While turning the diaphragm, fix it onto the screw of the center rod. [Fig.6.11]

<NOTE>

- Be sure to insert the diaphragm into the body until it reaches the end face of the body securely.

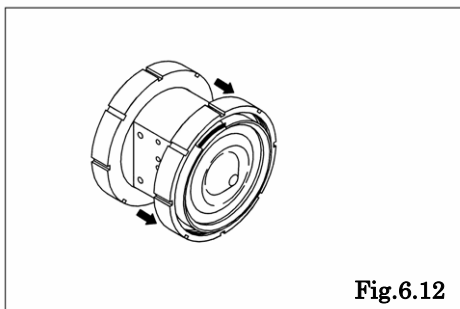

- While pushing the diaphragm toward the outside, attach the O ring onto the groove. [Fig.6.12]

<NOTE>

- After attaching the O ring, be sure to push the diaphragm to the original position. [Fig.6.13]
- Make sure that there is not any dust on the seal surface and that any sealed part cannot be damaged.
- Replace the locking nut with a new one regardless of its condition.
- Tighten the bolts on a diagonal line with even torque.
- Be sure to fix the bush into the diaphragm securely.
- Be sure to fix the diaphragm into the body until it reaches the end face of the body securely.

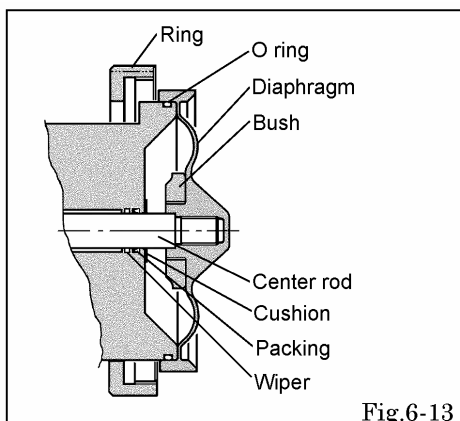

7. Pilot Valves, Valve Seats and Spring

7.1 Removal

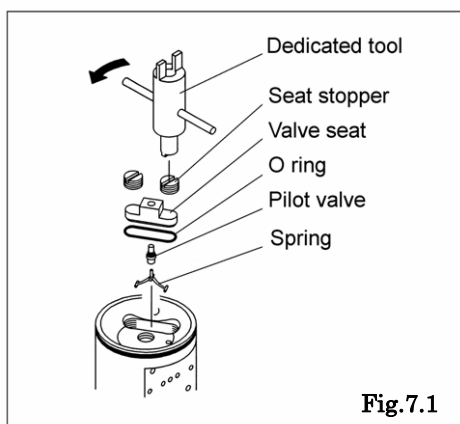

- Remove the diaphragm and center rod. (See Section [6.1 Removal])
- Use the dedicated tool①(pilot valve remover) to remove the 2 seat stoppers. [Fig.7.1]
- Remove the O ring, valve seat and pilot valve. [Fig.7.1]

7.2 Inspection

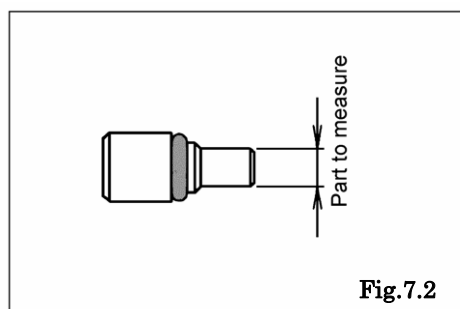

- Pilot valve assembly [Fig.7.2]
Measure the diameter, and if it is out of the allowable range, replace the pilot valve assembly with a new one.

Allowable range	
DP-10Fs	$\phi 4.8 \sim \phi 5.0$ mm
DP-20Fs	

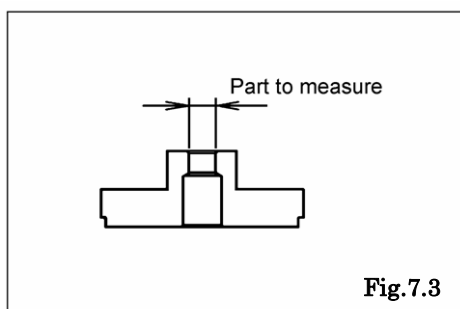

- Valve seat [Fig.7.3]
Measure the inside diameter, and if it is out of the allowable range, replace the valve seat with a new one.

Allowable range	
DP-10Fs	$\phi 7.0 \sim \phi 7.2$ mm
DP-20Fs	

- Spring [Fig.7.1]
Be sure to replace the spring with a new one when disassembling the pump regardless of its condition.
- O ring [Fig.7.1]
If the O ring is worn out or damaged, replace it with a new one.

7.3 Installation

For installation, see [Exploded View] on the separate sheet and install in the reverse order of disassembly.

<NOTE>

- Be careful not to remove the O ring located on the valve seat when installing any part to the pump.
- Be sure to fix the seat stopper into the body until it reaches the end face of the body securely.
- Make sure that there is no dust on the seal surface and that the seal surface cannot be damaged.
- Use the dedicated tool to attach the seat stopper.

8. Retightening of Tie rods

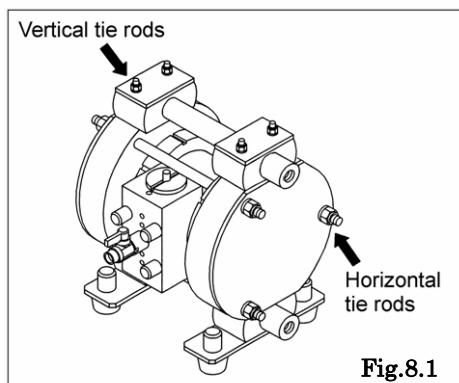

- Since the dimensions of this pump may vary according to the temperature or with the passage of time due to the characteristics of its material: resin. Therefore, check to see if any liquid material leaks at each sealed portion periodically, and retighten the parts indicated with arrow marks.
- The torque should be applied:
 - ① immediately before you use the pump,
 - ② during inspection to be performed every six months
 - ③ during inspection to be performed every year if you use the pump in the clean room, that is, if the pump is used within $\pm 5^{\circ}\text{C}$ of the temperature variation.
 - ④ if any leak of liquid or material is detected with the daily inspection.

Retightening torque of the tie rods

	Horizontal tie rods	Vertical tie rods
DP-10Fs	4 N·m	2 N·m
DP-20Fs		

<NOTE>

- Retighten the tie rod retainer nuts with even force.
- Retighten the horizontal tie rods, and then the vertical tie rods in this order. [Fig.8.1]

9. Instructions for applying lubrication

9.1 Applying lubricant to the Packing

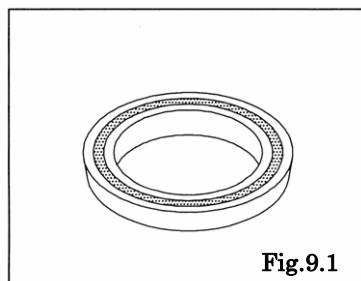

- Apply plenty of lubricant into the groove (V) of the packing.
- <NOTE>
- Be careful that no aeration occurs when applying lubricants.

9.2 Applying Lubricant to the Center Rod

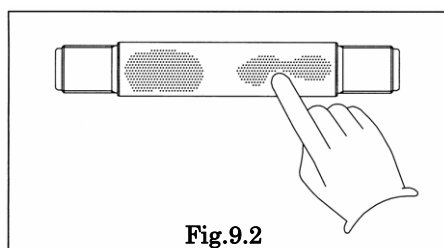

- Apply lubricant to the whole surface of center rod.

9.3 Assemble

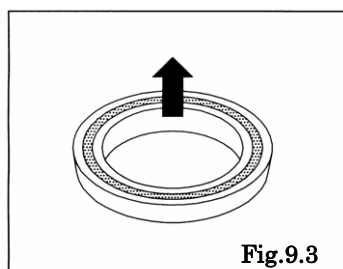

- The V Packing must be installed into body with the V facing out towards the air chambers
- <NOTE>
- In cases where the packing is installed incorrectly air leakage will occur.

Manufactured by

YAMADA CORPORATION

INTERNATIONAL DEPARTMENT

No.1-3, 1-Chome, Minami-Magome, Ohta-Ku, Tokyo, 143-8504, Japan

PHONE : +81-(0)3-3777-0241

FAX : +81-(0)3-3777-0584

201112 NDP150M