

MAINTENANCE MANUAL YAMADA AIR-OPERATED DIAPHRAGM PUMP

**DP-5F
DP-5FH
DP-10F
DP-20F
DP-25F
DP-38F**

WARNING



- For your own safety, be sure to read these procedures carefully before performing maintenance on this product. After reading this document, be sure to keep it handy for future reference.

This maintenance manual covers what you should know about maintenance of the Yamada DP-F series Diaphragm Pumps.

This edition is based on the standards for the March 2011 production run. Remember, the specifications are always subject to change; therefore, some of the information in this edition may not apply to new specifications.

Warnings and Cautions

For safe use of this product, be sure to note the following: In this document, warnings and cautions are indicated by symbols. These symbols are for those who will operate this product and for those who will be nearby, for safe operation and for prevention of personal injury and property damage. The following warning and caution symbols have the meanings described below. Be sure to remember their meanings.



WARNING : If you ignore the warning described and operate the product in an improper manner, there is danger of serious bodily injury or death.



CAUTION : If you ignore the caution described and operate the product in an improper manner, there is danger of personal injury or property damage.

Furthermore, to indicate the type of danger and damage, the following symbols are also used along with those mentioned above:



This symbol indicates a DON'T, and will be accompanied by an explanation on something you must not do.



This symbol indicates a DO, and will be accompanied by instructions on something you must do in a certain situation.

WARNING



- Before starting maintenance work, cut off the feed air and clean the pump. If air pressure or residue remain in the pump, there is danger of explosion, or possible poisoning resulting in serious injury or death if chemicals adhere to the skin or are accidentally swallowed. (For details on cleaning the pump, refer to Chapter 6 of the operating manual.)
- When replacing parts, be sure to use the recommended genuine parts or Equivalents. Use of other parts may cause a malfunction of the product. (Refer to Exploded View and Reminder to order correct item on the separate sheets.)



CAUTION



- When it is instructed that special tools must be used, be sure to use the specified tools. Otherwise, the pump may be damaged.
- Refer to 10.1 "Specifications" in the Operation Manual. Also, remember that the pump is heavy, and extreme care must be taken when lifting it.

Table of Contents

| | |
|---|----|
| ·Warnings and Cautions | |
| ·Table of Contents | |
| 1.Principles of operation | 1 |
| 2.Tools, etc. | |
| 2.1 General tools..... | 1 |
| 2.2 Special tools..... | 2 |
| 2.3 Misc. | 2 |
| 3.Ordering Replacement parts | 2 |
| 4.Balls, Flat valves and Valve seats | |
| 4.1 Removal | 3 |
| 4.2 Inspection | |
| ■ Ball valve types | 4 |
| ■ Flat valve types | 4 |
| 4.3 Installation | 4 |
| 5.Diaphragm and Center rod | |
| 5.1 Removal | |
| ■ DP-5F | 5 |
| ■ DP-5FH | 6 |
| ■ DP-10F, DP-20F, DP-25F, DP-38F | 7 |
| 5.2 Inspection..... | 8 |
| 5.3 Installation | 9 |
| 6.Pilot valve Assembly and Bushing | |
| 6.1 Removal | |
| ■ DP-5F, DP-5FH | 10 |
| ■ DP-10F, DP-20F, DP-25F, DP-38F | 10 |
| 6.2 Inspection..... | 10 |
| 6.3 Installation | 10 |
| 7.C Spool valve Assembly and Sleeve Assembly | |
| 7.1 Removal | |
| ■ DP-5F, DP-5FH, DP-10F, DP-20F | 11 |
| ■ DP-25F, DP-38F..... | 11 |
| 7.2 Inspection..... | 12 |
| 7.3 Installation | 12 |
| 8. Instructions for applying lubrication..... | 13 |
| 9. Retightening of Tie rods..... | 13 |

1.Principles of operation

There are two diaphragms fixed to the center rod, one at each end. When compressed air is supplied to air chamber b (right side, see Fig.1.1), the center rod moves to the right, the material in material chamber B is pushed out, and at the same time material is sucked into material chamber A.

When the center rod is moved full-stroke to the right, the air switch valve is switched, compressed air is sent to air chamber a (left side, see Fig.1.2), and the center rod moves to the left. The material in material chamber A is pushed out, and at the same time material is sucked into material chamber B.

Through repetition of this operation, material is repeatedly taken in and discharged out.

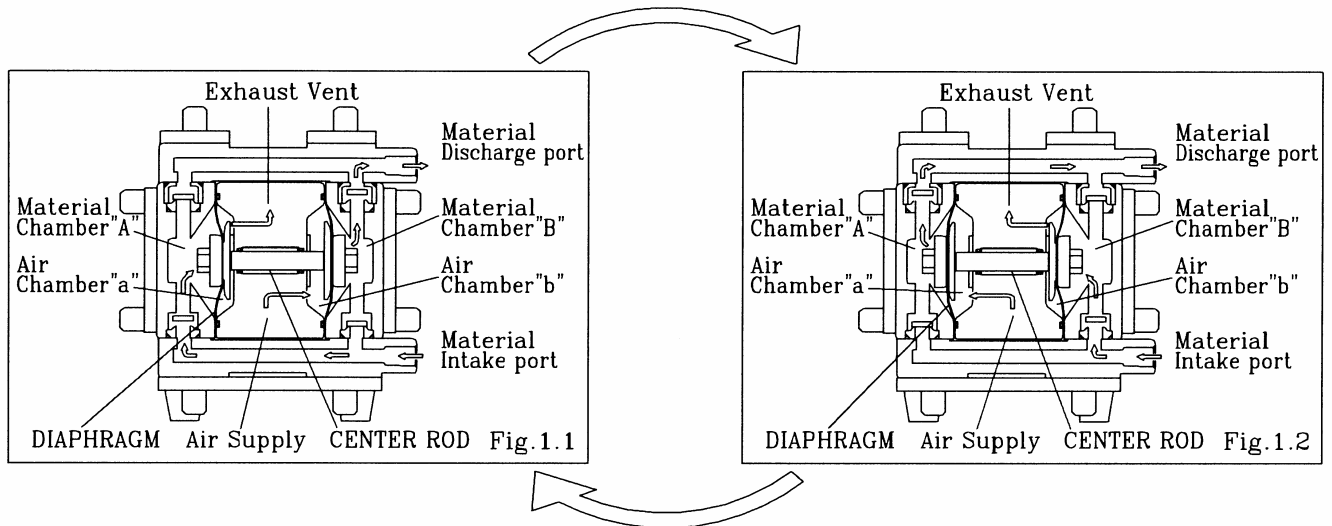

2.Tools, etc.

2.1 General tools

| Tool name | Socket wrench | | | Open-end wrench | | | | Plyer | Adjustable angle wrench | Hexagon wrench |
|-----------|---------------|----|----|-----------------|----|----|----|-------|-------------------------|----------------|
| Size (mm) | 10 | 13 | 17 | 10 | 13 | 17 | 27 | | | 2 |
| DP-5F | ○ | | | ○ | | | | ○ | | |
| DP-5FH | ○ | | | ○ | | | ○ | | ○ | ○ |
| DP-10F | ○ | ○ | | ○ | ○ | | | ○ | | |
| DP-20F | ○ | ○ | | ○ | ○ | | | ○ | | |
| DP-25F | | ○ | ○ | | ○ | ○ | | | ○ | |
| DP-38F | | ○ | ○ | | ○ | ○ | | | ○ | |

2.2 Special tools(sold separately)

·Pilot valve remover

Purpose: Remove the pilot valve and cap (except with the DP-5F, DP-5FH)

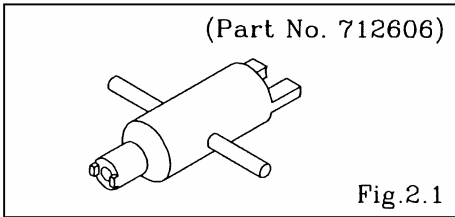

·Sleeve remover

Purpose: For removing sleeves

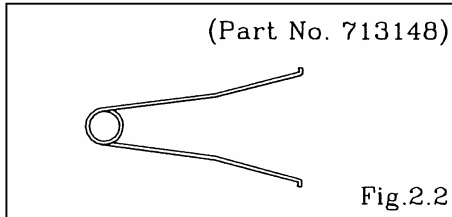

·Cap and disk remover

Purpose: Removing the center disk and cap (DP-5F)

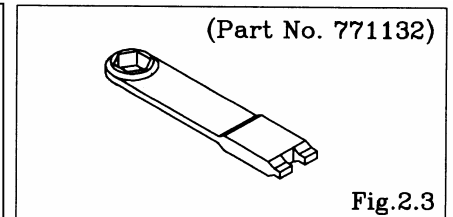

·PP wrench

Purpose: Removing the center disk (DP-10F, DP-20F, DP-25F, DP-38F)

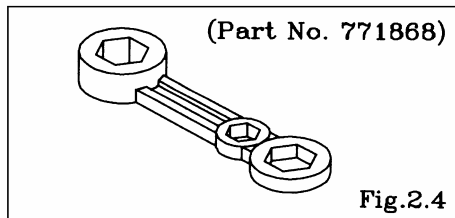

·Torque wrench

Purpose: Retightening the center disk

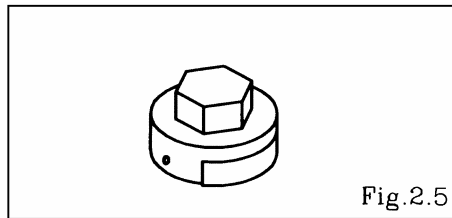

Part.No.

804307 DP-5F

804308 DP-10F

804309 DP-20F

804310 DP-25F, DP-38F

2.3 Misc.

·Assembly lubricating oil

Solvay Solexis K.K. FOMBLIN grease AR555 or equivalent

·Nuts

M6X1 (DP-5F, DP-5FH) , M8X1.25 (DP-10F)

M10X1.5 (DP-20F) , M14X1.5 (DP-25F) , M16X1.5(DP-38F)

3.Ordering Replacement parts

For accurate and speedy shipment of parts, be sure to order the right parts for your model to distributor. Indicate the part numbers, descriptions, and quantities.

4. Balls, Flat valves and Valve seats

4.1 Removal

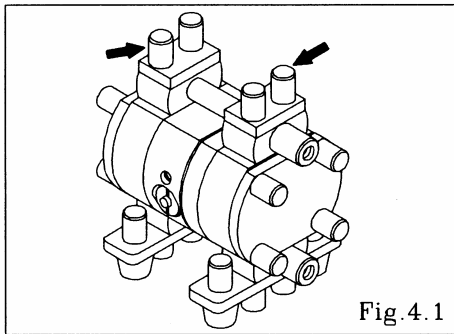

- Remove the 8 caps from the both sides of the upright tie rod. [Fig.4.1]

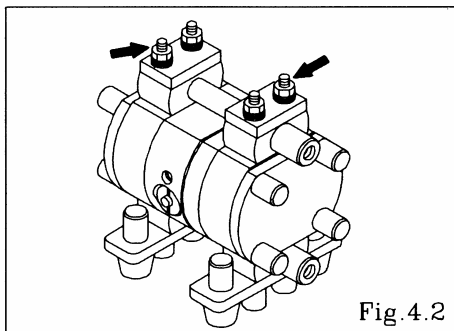

- Remove the 4 retainer nuts from the upper side of the upright tie rods, and remove the reinforcement plate, O ring (DP-25F, DP-38F) and out manifold. [Fig.4.2]

<NOTE>

- When the retainer nuts both sides of the upright tie rods remove, the in manifold removes.

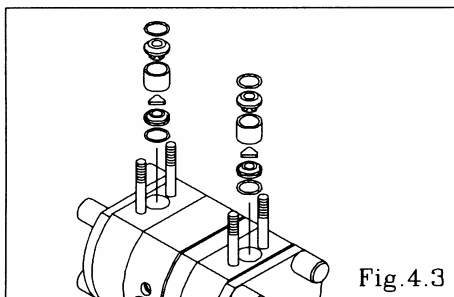

- Remove the O ring, valve stopper, valve guide, ball or flat valve and valve seat. [Fig.4.3]

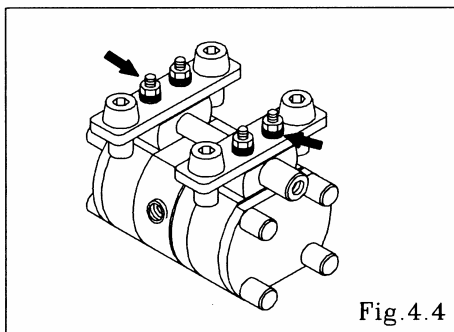

- Turn over the main body assembly. [Fig.4.4]
- Pull out the upright tie rods, and remove the base, O ring (DP-25F, DP-38F) and in manifold. [Fig.4.4]

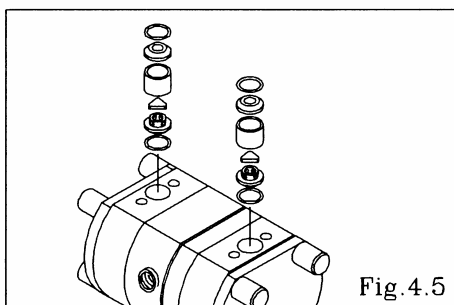

- Remove the O ring, valve seat, ball or flat valve, valve guide and valve stopper. [Fig.4.5]

4.2 Inspection

■ Ball valve types

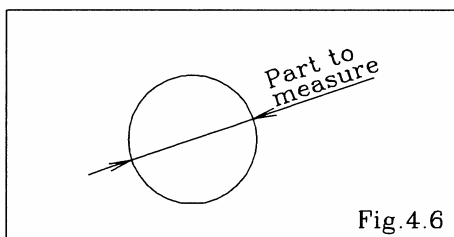

▪ Ball [Fig.4.6]

Measure the outside diameter, and if it is outside the usable range, replace the ball.

Usable range of Ball

| | |
|----------------|--------------------|
| DP-10F | SØ14.3 ~ SØ16.3 mm |
| DP-20F | SØ24.3 ~ SØ27.8 mm |
| DP-25F, DP-38F | SØ31.5 ~ SØ36.0 mm |

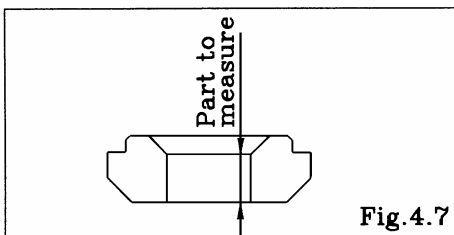

▪ Valve seat [Fig.4.7]

Measure the dimension shown at left, and if it is outside the usable range, replace the valve seat.

Usable range of Valve seat

| | |
|----------------|--------------|
| DP-10F | 2.4 ~ 6.0 mm |
| DP-20F | 2.8 ~ 7.0 mm |
| DP-25F, DP-38F | 3.2 ~ 7.5 mm |

■ Flat valve types

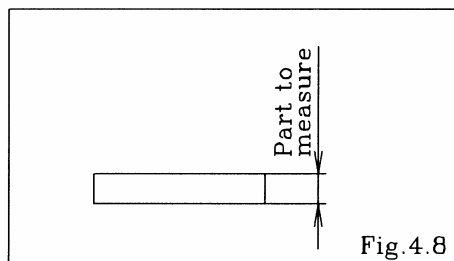

▪ Flat valve [Fig.4.8]

Measure the dimension shown at left, and if it is outside the usable range, replace the flat valve. If the flat valve is worn out or cracked, replace it.

Usable range of Flat valve

| | |
|----------------|--------------|
| DP-5F, DP-5FH | 2.4 ~ 3.1 mm |
| DP-10F | 3.6 ~ 4.6 mm |
| DP-20F | 4.8 ~ 6.1 mm |
| DP-25F, DP-38F | 5.6 ~ 7.2 mm |

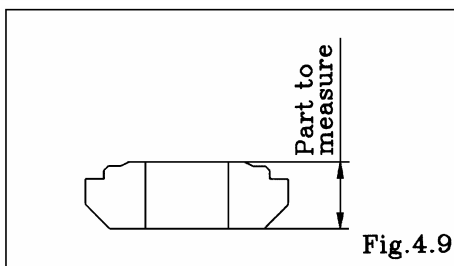

▪ Valve seat [Fig.4.9]

Measure the dimension shown at left, and if it is outside the usable range, replace the valve seat.

Usable range of Valve seat

| | |
|----------------|---------------|
| DP-5F, DP-5FH | 5.8 ~ 7.2 mm |
| DP-10F | 6.8 ~ 8.2 mm |
| DP-20F | 8.2 ~ 10.2 mm |
| DP-25F, DP-38F | 9.6 ~ 12.2 mm |

4.3 Installation

For installation, see [Exploded View] on the separate sheet and install in the reverse order of disassembly.

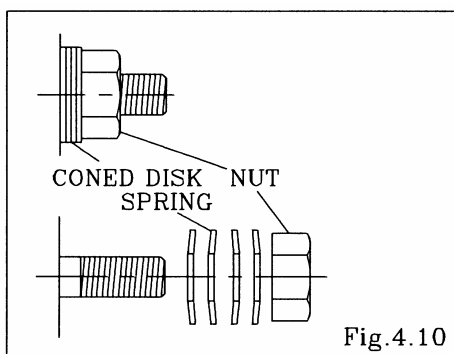

Tightening torque for vertical tie rods

| | |
|---------------------------------|--------|
| DP-5F, DP-5FH DP-10F, DP-20F | 5 N·m |
| DP-25F | 7 N·m |
| DP-38F | 15 N·m |

<NOTE>

- Make sure there is no dust on the seal surface and the seal is not damaged.
- Replace the PTFE O ring regardless of its condition.
- Make sure that direction the coned disk springs. [Fig.4.10]
- Retighten the tie rods before starting the pump. (See [8. Retightening of tie rods])

5. Diaphragm and Center rod

5.1 Removal

■DP-5F

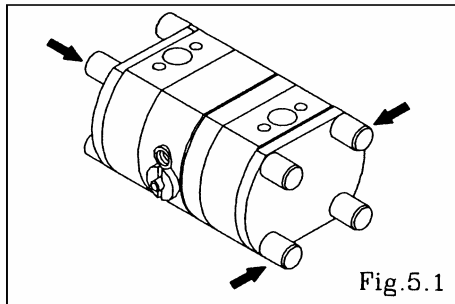

- Remove the ball, flat valve and valve seat etc. (see [4.1 Removal])
- Remove the 8 caps from the both sides of horizontal tie rods. [Fig.5.1]

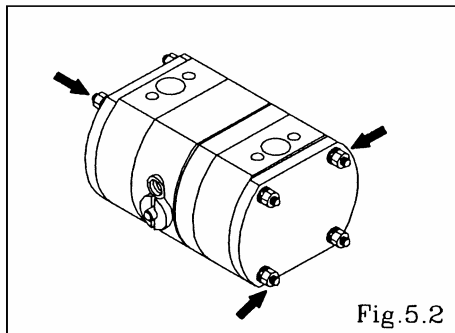

- Remove the 8 retainer nuts from the both sides of horizontal tie rods, and remove the reinforcement plate and out chamber. [Fig.5.2]

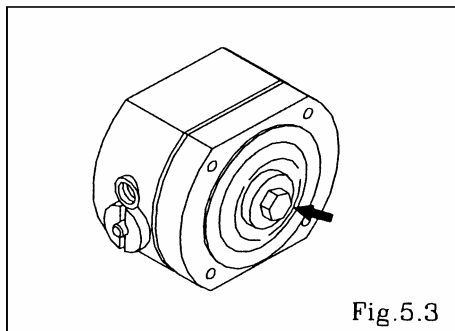

- Remove the center disk using the cap and disk remover. (special tool: Part No. 771132). [Fig.5.3]
- After the center disk (outside) has been removed, remove the diaphragm and the center disk (inside).
- Remove the center disk and center rod from the opposite side of the main body.

<NOTE>

- When the diaphragms are removed, the main body is separated 2 pieces. For easy work, leave the tie rods or bolts fastened temporarily before remove the diaphragms.

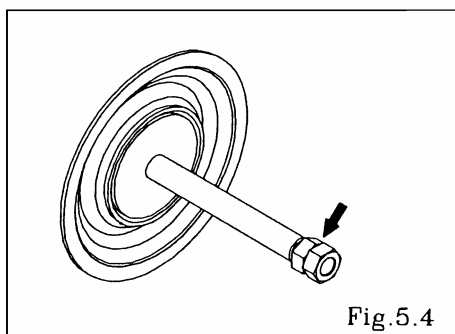

- Fix a double nut to one end of the center rod and take the diaphragm and center disk off the opposite end. [Fig.5.4]
Be careful not to scratch or score the center rod.

■DP-5FH

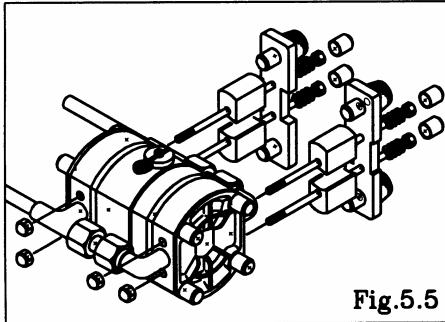

- Turn the main body assembly sideways as shown in [Fig. 5.5]
- Remove the 4 caps located on the bottom side of each vertical tie rod. [Fig. 5.5]
- Remove four hexagon cap nuts from the upper side of each tie rod. [Fig. 5.5]
- Pull out four vertical tie rods, and then remove the base and the spacer.

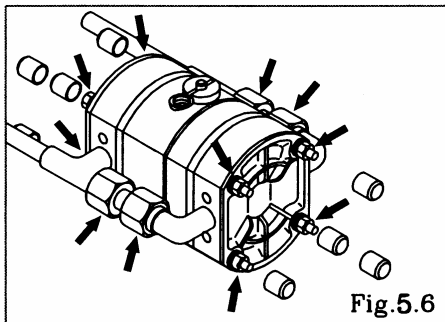

- Loosen four fittings located on the top and bottom of the out chamber assembly. [Fig. 5.6]
- Remove the 8 caps from both ends of the horizontal tie rods. [Fig. 5.6]
- Remove the 8 nuts from both ends of the horizontal tie rods, and then remove the out chamber assembly and tube. [Fig. 5.6]

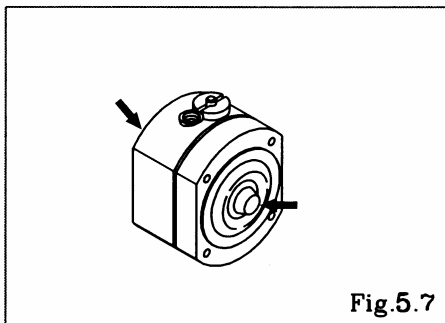

- Manually turn and remove the diaphragm assembly. [Fig. 5.7]
- When either of the diaphragm assemblies is removed, remove it from the center rod too.

<NOTE>

- When you remove the diaphragm, the main body is disassembled at the same time. Therefore, temporarily fix the main body with the tie rods or other parts.

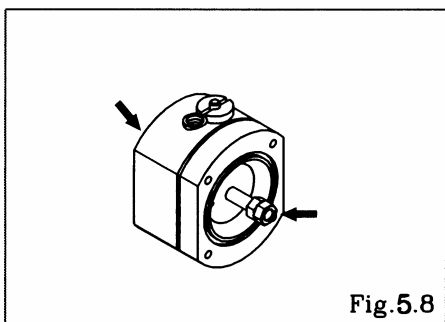

- Use the double nut to remove the diaphragm assembly located on the opposite side from the center rod. [Fig. 5.8]

■DP-10F, DP-20F, DP-25F, DP-38F

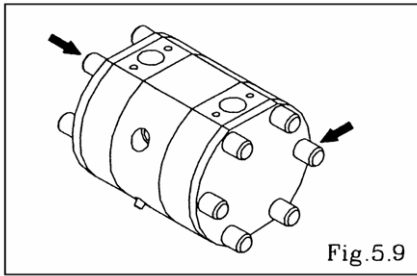

- Remove the ball or flat valve and valve seat etc. (see [4.1 Removal])
- Remove the 12 (16 on DP-38F) caps from the both sides of the horizontal tie rods. [Fig.5.9]

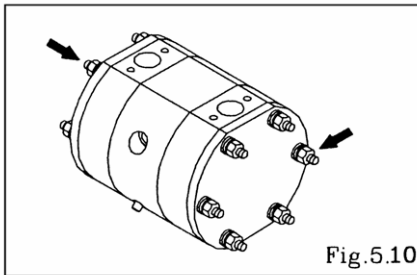

- Remove the 12 (16 on DP-38F) retainer nuts from the both sides of horizontal tie rods, and remove the reinforcement plate, O ring (DP-25F, DP-38F) and out chamber. [Fig.5.10]

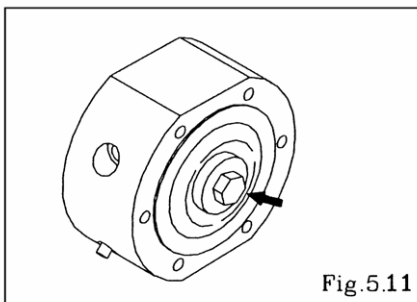

- Remove the center disk from one side using the PP wrench (special tool: Part No. 771868). [Fig.5.11]
- After the center disk (outside) has been removed, remove the diaphragm and the center disk (inside). Remove the center disk and center rod from the opposite side of the main body.

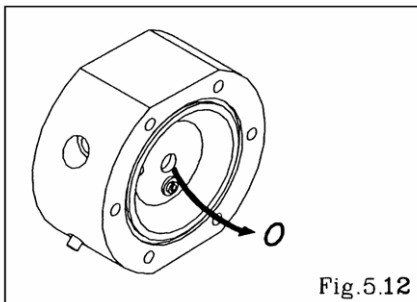

- Remove the packing from the body. [Fig.5.12]

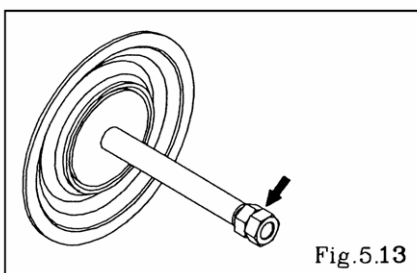

- Fix a double nut to one end of the center rod and take the diaphragm and center disk off the opposite end. [Fig.5.13]
Be careful not to scratch or score the center rod.

5.2 Inspection

- Diaphragm

If the diaphragm is worn out or damaged, replace it.
Never replace just one diaphragm.

Guideline of diaphragm life

| | |
|----------------|------------------|
| DP-5F, DP-5FH | 30,000,000 cycle |
| DP-10F | 12,000,000 cycle |
| DP-20F | 6,000,000 cycle |
| DP-25F, DP-38F | 6,000,000 cycle |

(When used with clean water at room temperature)

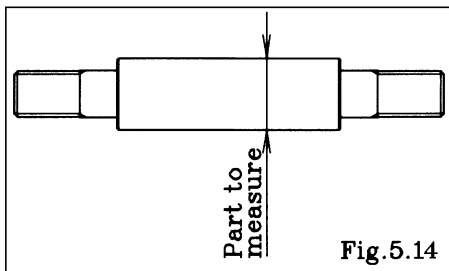

- Center rod [Fig.5.14]

Measure the diameter, and if it is outside the usable range, replace the center rod.

Usable range of center rod

| | |
|----------------|----------------------|
| DP-5F, DP-5FH | ∅ 9.95 ~ ∅ 10.00 mm |
| DP-10F, DP-20F | ∅ 13.95 ~ ∅ 14.00 mm |
| DP-25F | ∅ 23.95 ~ ∅ 24.00 mm |
| DP-38F | ∅ 29.85 ~ ∅ 29.95 mm |

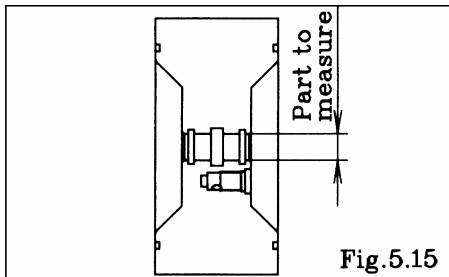

- Body [Fig.5.15]

Measure the inside diameter, and if it is outside the usable range, replace the body.

Usable range of body

| | |
|----------------|----------------------|
| DP-10F, DP-20F | ∅ 14.03 ~ ∅ 14.10 mm |
| DP-25F | ∅ 24.00 ~ ∅ 24.10 mm |
| DP-38F | ∅ 30.00 ~ ∅ 30.10 mm |

- Packing

If the packing is worn out or cracked, replace it.

5.3 Installation

For installation, see [Exploded View] on the separate sheet and install in the reverse order of disassembly.

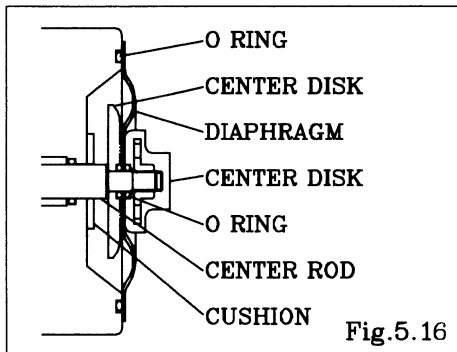

- Install the diaphragm with the convex side outside. [Fig.5.16]
- Insert the O ring. (Do not operation for a DP-5FH)
- Turn the diaphragm assembly with your hand until it stops, and assemble it. (DP-5FH)

Tightening torque for center rod

| | |
|----------------|--------|
| DP-5F, DP-5FH | 6 N·m |
| DP-10F | 16 N·m |
| DP-20F | 21 N·m |
| DP-25F, DP-38F | 45 N·m |

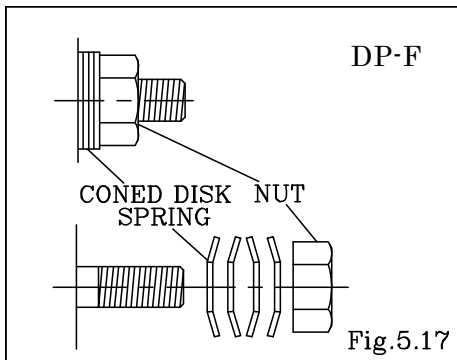

Tightening torque for Horizontal tie rods

| | |
|----------------|--------|
| DP-5F, DP-5FH | 5 N·m |
| DP-10F, DP-20F | 7 N·m |
| DP-25F | 10 N·m |
| DP-38F | 15 N·m |

<NOTE>

- Make sure there is no dust on the seal surface in order to prevent seal damaged.
- Tighten the bolts that balance should be equal from both side on diagonal line with even torque.
- Make sure that direction the coned disk springs. [Fig.5.17]
- Use six coned disk spring for horizontal tie rod. (DP-5FH) [Fig.5.18]
- Install the pilot valve, bushing and guide certainly. (DP-5F) (see [6.3 Installation]).
- Retighten the tie rods before starting the pump. (See [8. Retightening of tie rods])

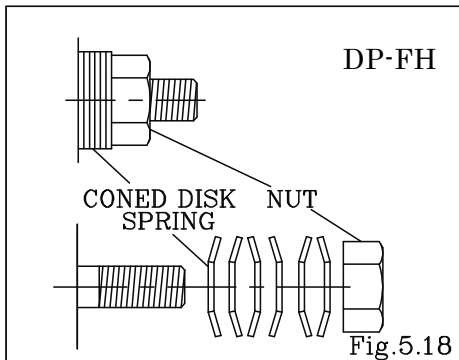

6. Pilot valve Assembly and Bushing

6.1 Removal

■DP-5F, DP-5FH

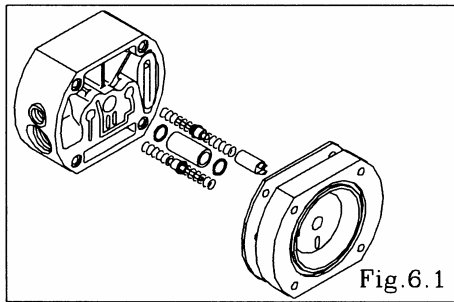

- Remove the diaphragm and center rod (see [5.1 Removal]).
- Remove the body. [Fig.6.1]
- Draw out the pilot valve assembly. [Fig.6.1]
- Remove the O ring and bushing. [Fig.6.1]
(O ring is not included in DP-5FH).

■DP-10F, DP-20F, DP-25F, DP-38F

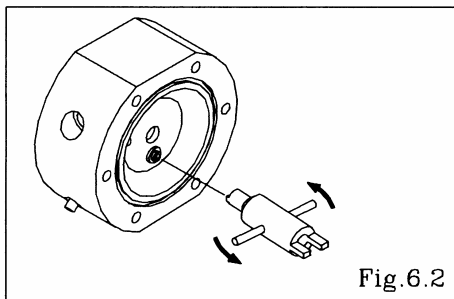

- Remove the diaphragm and center rod (see [5.1 Removal]).
- Remove the valve seat using pilot the valve remover (special tool: Part No. 712606).
- Remove the O ring and pilot valve Assembly. [Fig.6.2]

6.2 Inspection

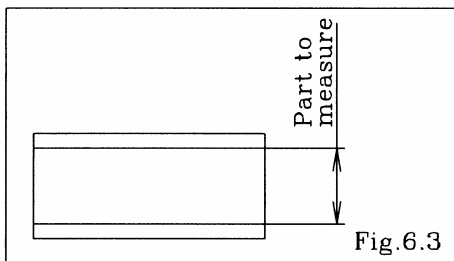

- Bushing (DP-5F, DP-5FH) [Fig.6.3]
Measure the inside diameter, and if it is outside the usable range, replace the bushing.

Usable range of bushing

| | |
|--------|---------------------|
| DP-5F | Ø10.1 ~ Ø 10.3 mm |
| DP-5FH | Ø10.03 ~ Ø 10.07 mm |

- O rings
If the O ring is worn out or cracked, replace it.
- Pilot valve assembly
If the pilot valve is worn out or cracked, replace it.

6.3 Installation

For installation, see [Exploded View] on the separate sheet and install in the reverse order of disassembly.

<NOTE>

- Make sure there is no dust on the seal surface and the seal not damaged.
- Use the pilot valve remover (special tool: Part No. 712606).
- Retighten the tie rods before starting the pump.
(See [8. Retightening of tie rods])

7. C Spool valve Assembly and Sleeve Assembly

7.1 Removal

■DP-5F, DP-5FH, DP-10F, DP-20F

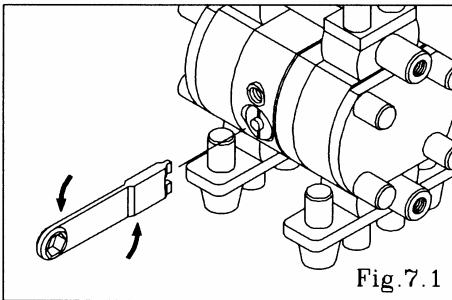

- Remove the cap using the cap and disk remover (special tool: Part No. 771132). (DP-5F, DP-5FH) [Fig.7.1]
- Remove the cap using the pilot valve remover (special tool: Part No. 712606). (DP-10F, DP-20F) [Fig.7.1]

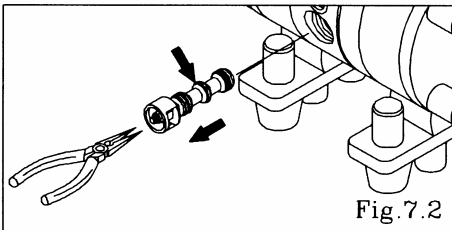

- Pull out the C spool valve assembly using the plier, and remove the seal ring from the C spool valve assembly. [Fig.7.2]

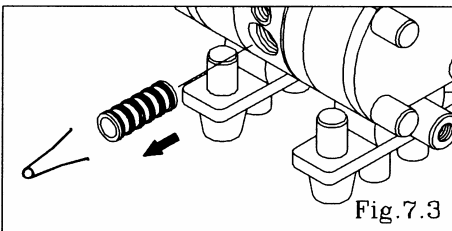

- Remove the sleeve using the sleeve remover (special tool: Part number 713148). [Fig.7.3]

■DP-25F, DP-38F

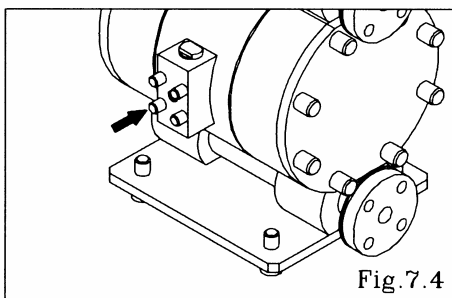

- Remove the 4 cap from the stud bolts. [Fig.7.4]

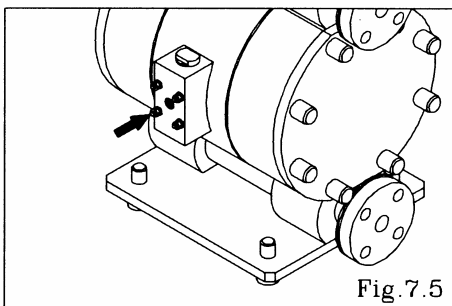

- Remove the 4 retainer nuts from the valve body, and remove the valve body. [Fig.7.5]

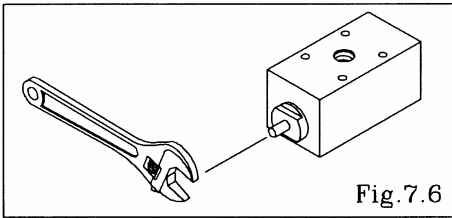

- Remove the caps both sides of valve body using the adjustable angle wrench, and remove the cushion.[Fig.7.6]

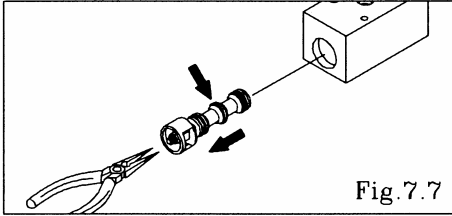

- Draw out the C spool valve assembly using the pleyer, and remove the seal rings from the C spool valve assembly. [Fig.7.7]

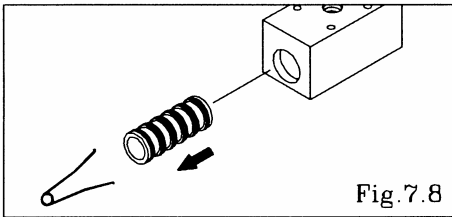

- Remove the sleeve from the valve body using the sleeve remover (special tool: Part No. 713148). [Fig.7.8]

7.2 Inspection

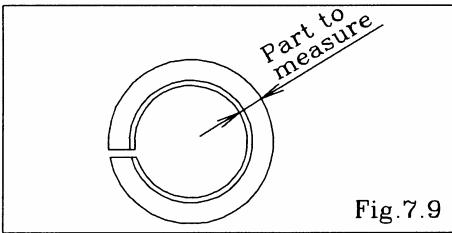

- C Spool valve Assembly
Seal ring [Fig.7.9]
Measure the inside thick diameter, and if it is outside the usable range, replace the c spool valve assembly.
If the seal ring is worn out or cracked, replace c spool Valve assembly.

Usable range of Seal ring

| | |
|----------------|----------------|
| DP-5F, DP-5FH | 1.40 ~ 1.45 mm |
| DP-10F, DP-20F | 1.85 ~ 1.90 mm |
| DP-25F, DP-38F | 2.55 ~ 2.65 mm |

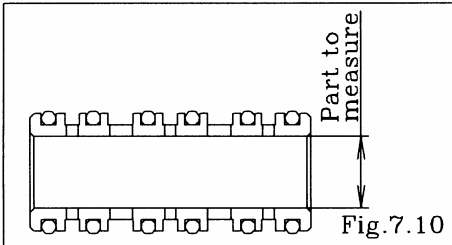

- Sleeve Assembly[Fig.7.10]
Measure the inside diameter, and if it is outside the usable range, replace the sleeve assembly.

Usable range of Sleeve

| | |
|----------------------------------|----------------------|
| DP-5F, DP-5FH | Ø 9.50 ~ Ø 9.55 mm |
| DP-10F, DP-20F DP-25F, DP-38F | Ø 15.80 ~ Ø 15.85 mm |

- O ring
If the O ring is worn out or cracked, replace it.

<NOTE>

- C Spool valve assembly and sleeve assembly should be replaced as a complete set.

7.3 Installation

For installation, see [Exploded View] on the separate sheet and install in the reverse order of disassembly.

Tightening torque for Valve body installation bolts

| | |
|---------------|-------|
| DP-25F,DP-38F | 7 N·m |
|---------------|-------|

<NOTE>

- Make sure there is no dust on the seal surface and it is not damaged.
- Retighten the tie rods before starting the pump.
(See [8. Retightening of tie rods])

8. Instructions for applying lubrication

8.1 Applying lubricant to the Packing

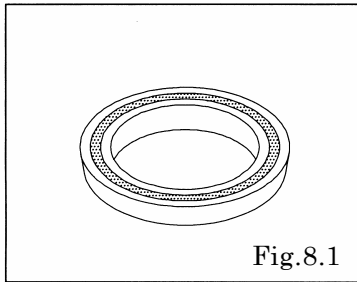

Fig.8.1

- Apply plenty of lubricant into the groove (V) of the packing. [Fig.8.1]
- <NOTE>
 - Be careful that no aeration occurs when applying lubricants.

8.2 Applying Lubricant to the Center Rod

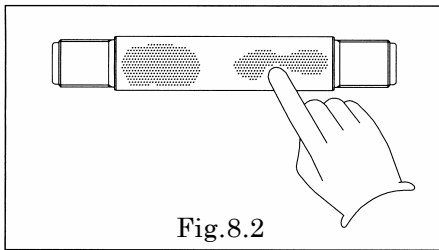

Fig.8.2

- Apply lubricant to the whole surface of center rod. [Fig.8.2]

8.3 Assemble

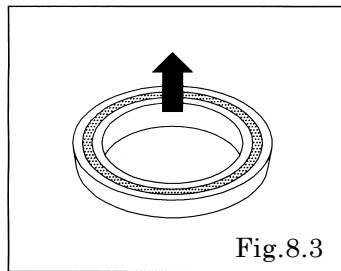

Fig.8.3

- The V Packing must be installed into body with the V facing out towards the air chambers. [Fig.8.3]

<NOTE>

- In cases where the packing is installed incorrectly air leakage will occur.

9. Retightening of Tie rods

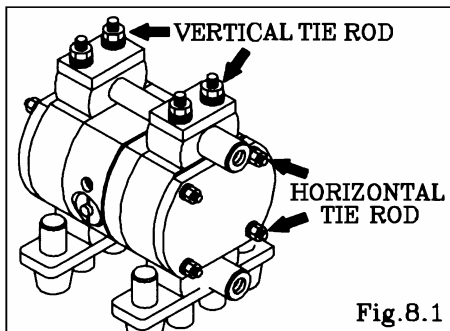

Fig.8.1

- The torque should be applied on the occasion of:
 - (1) Right before the pump to use.
 - (2) There are any leaks of material on daily inspecting a pump.

Retightening of tie rods and torque

| | Horizontal tie rods | Vertical tie rods |
|--------|---------------------|-------------------|
| DP-5F | 4 N·m | 4 N·m |
| DP-5FH | | |
| DP-10F | 6 N·m | 6 N·m |
| DP-20F | | |
| DP-25F | 8 N·m | 6 N·m |
| DP-38F | 13 N·m | 13 N·m |

<NOTE>

- Fasten the nut (tie rods) on a diagonal line alternately with even force.
- Retighten the horizontal tie rods and then the vertical tie rods. [Fig.8.1] (Fig.8.1 shows the DP-5F.)
- Be careful to installation directions of a spring washer. [Fig.8.2]

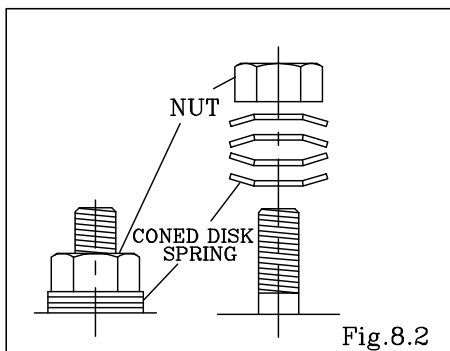

Fig.8.2

Manufactured by

YAMADA CORPORATION

INTERNATIONAL DEPARTMENT

No.1-3, 1-Chome, Minami-Magome, Ohta-Ku, Tokyo, 143-8504, Japan

PHONE : +81-(0)3-3777-0241

FAX : +81-(0)3-3777-0584

201112 NDP032M